

Campanas de cocina decorativas.

Características

Compuerta antirretorno.
Filtro metálico.
Selector velocidades/luz.
Evacuación superior.
Reductor de conducto descarga de Ø150 mm a Ø120 mm.

Modos funcionamiento



Salida
al exterior



Recirculación
con 2 filtros de carbono
(accesorio)

DIMENSIONES (mm)

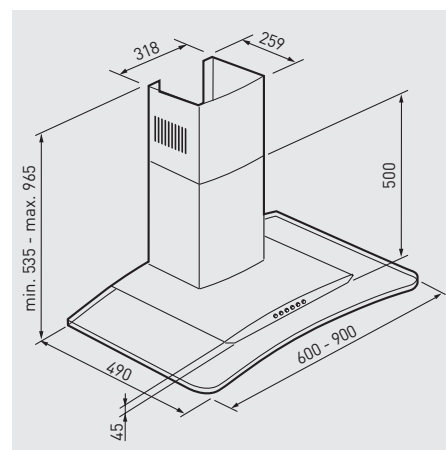

CARACTERÍSTICAS TÉCNICAS

Modelo	Color	Anchura campana (mm)	Ø Tubo descarga (mm)	Caudal (m³/h)	Tensión	Velocidades	Número de motores	Potencia motor (W)	Iluminación	Intensidad total (A)	Nivel presión sonora* (dB (A))
ONDA CRISTAL 600 E	INOX/CRISTAL	600	150	382	230V 50/60Hz	3	1	135	Led 2x2,5W	0,61	50
ONDA CRISTAL 900 E	INOX/CRISTAL	900	150	382	230V 50/60Hz	3	1	135	Led 2x2,5W	0,61	50

* Medido a 1,5 metros, a descarga libre.

ACCESORIOS



GSA-125 M0
GSA-150 M0
Conducto flexible de aluminio.



CX-125/215
Brida de sujeción.



PER-100 W
PER-125 W
Persiana de sobrepresión.



GRA-100
GRA-150
Reja de extracción de aluminio.

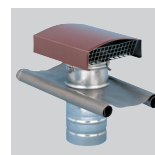

CT-125
CT-150
Sombrero de tejado.

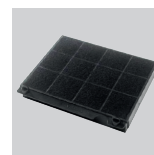

FILTRO CARBON BOX E, ONDA CRISTAL E
(1 ud. por campana)