



Campanas de cocina tradicionales.  
**Campana tipo empotrable.**

**Características**

Compuerta antirretorno.  
Filtro metálico.  
Selector velocidades/luz.  
Evacuación superior.

**Modos funcionamiento**



Salida  
al exterior



Recirculación  
con filtro de carbono  
(accesorio)

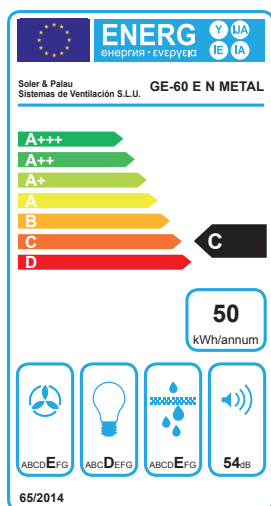

**DIMENSIONES (mm)**

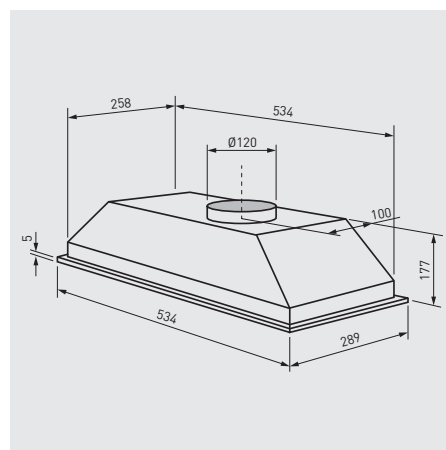

**CARACTERÍSTICAS TÉCNICAS**

Modelo	Color	Anchura campana (mm)	Ø Tubo descarga (mm)	Caudal (m³/h)	Tensión	Velocidades	Número de motores	Potencia motor (W)	Iluminación	Intensidad total (A)	Nivel presión sonora* (dB (A))
GE-60 E N METAL	GRIS	600	120	224	230V-50/60Hz	3	1	75	Led 2x3W	0,35	42

\* Medido a 1,5 metros, a descarga libre.

**ACCESORIOS**



**GSA-125 M0**  
Conducto flexible de aluminio.



**CX-125/215**  
Brida de sujeción.



**PER-100 W**  
Persiana de sobrepresión.



**GRA-100**  
Reja de extracción de aluminio.

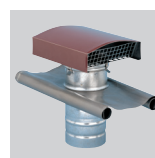

**CT-125**  
Sombrero de tejado.

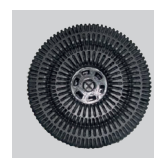

**FILTRO CARBON GE E N, GL E N, GET E**  
(2 uds. por campana)