

Range of centrifugal roof mounted fans in horizontal discharge format suitable for many roof extract ventilation applications, including housing ventilation, commercial offices, shopping malls, etc...

- Very low profile design.
- Base manufactured from galvanised sheet steel.
- Centrifugal backward curved impeller.
- Steel finger proof guard.
- Cowl manufactured from galvanised steel and aluminium cover.
- ON-OFF electrical isolation switch fitted.
- Models suitable for operation within ambient air temperatures between - 20°C up to +40°C.
- Fan speed adjustable with the potentiometer placed in the connection box or with an external control type REB ECOWATT.
- Analogical input with terminals in the terminal box to control the fan with 0-10V input signal.

#### Motors

Brushless EC motor, IP44, with thermal overload protection, suitable for single phase supply 230V±15%/50-60Hz.



#### Low profile

External rotor motor to limit the height of the fan.



#### Direct drive backward

centrifugal impeller with brushless EC motor.



#### Bird proof guard.

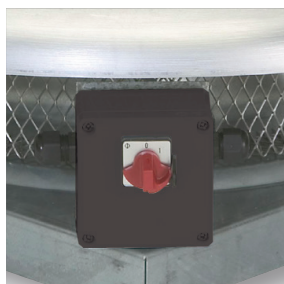

#### ON-OFF electrical isolated switch.



Range of centrifugal roof mounted fans in vertical discharge format suitable for many roof extract ventilation applications, including housing ventilation, commercial offices, shopping malls, etc...

- Very low profile design.
- Base manufactured from galvanised sheet steel.
- Centrifugal backward curved impeller.
- Steel finger proof guard.
- Cowl manufactured from galvanised steel and aluminium cover.
- ON-OFF electrical isolation switch fitted.
- Models suitable for operation within ambient air temperatures between - 20°C up to +40°C.
- Fan speed adjustable with the potentiometer placed in the connection box or with an external control type REB ECOWATT.
- Analogical input with terminals in the terminal box to control the fan with 0-10V input signal.

#### Motors

Brushless EC motor, IP44, with thermal overload protection, suitable for single phase supply 230V±15%/50-60Hz.



**Direct drive backward** centrifugal impeller with brushless EC motor.



**Bird proof guard.**



**ON-OFF electrical isolated** switch.



### TECHNICAL CHARACTERISTICS

Before installation check that the product electrical characteristics listed on the data plate label (Voltage, power, frequency, etc.) match those of the intended electrical supply.

Model	Input tension regul. (V)	Speed (rpm)	Maximum absorbed power (W)	Maximum absorbed current (A)	Maximum airflow (m <sup>3</sup> /h)	Sound pressure level* at 4m (dB(A))		Weight (kg)
						Inlet	Outlet	
CRHB-315 ECOWATT	10	1170	93	0,41	1.700	49	52	18
	8	1050	74	0,34	1.550	47	50	
	6	870	46	0,24	1.270	45	47	
	4	690	29	0,18	1.010	41	45	
	2	530	19	0,15	755	36	43	
CRHB-355 ECOWATT	10	1490	316	1,32	3.260	49	52	22
	8	1325	238	1,00	2.910	47	50	
	6	1075	131	0,57	2.360	44	48	
	4	830	66	0,31	1.810	39	43	
	2	585	31	0,18	1.280	34	36	
CRHB-400 ECOWATT	10	1450	467	1,96	4.255	54	60	23
	8	1245	344	1,45	3.550	51	57	
	6	1070	218	0,93	3.060	47	52	
	4	855	115	0,51	2.530	41	47	
	2	655	59	0,29	1.870	36	40	
CRVB-315 ECOWATT	10	1160	94	0,42	1.560	42	46	20
	8	1080	79	0,37	1.450	41	45	
	6	920	54	0,28	1.240	39	43	
	4	780	38	0,23	1.060	38	43	
CRVB-355 ECOWATT	10	1500	272	1,15	2.670	51	58	25
	8	1300	185	0,80	2.320	47	55	
	6	1100	116	0,52	1.970	43	50	
	4	870	64	0,32	1.510	38	44	
CRVB-400 ECOWATT	10	1450	424	1,76	3.710	55	61	26
	8	1300	333	1,40	3.330	52	58	
	6	1090	199	0,86	2.780	47	54	
	4	865	106	0,47	2.240	41	48	

\* Sound pressure level measured at 4m, roof fan installed on a plan, at the 3 - 7 - 11 - 15 and 19 working points of the performance curve.

PERFORMANCE CURVES - ACOUSTIC CHARACTERISTICS CRHB ECOWATT

- $q_v$ : Airflow in  $m^3/h$ .
- $p_{st}$ : Static pressure in Pa.
- P: Input power in W.
- SFP: Specific fan power in  $W/m^3/s$  (blue curves).
- Performance data in accordance with ISO 5801 and AMCA 210-99 Standards.

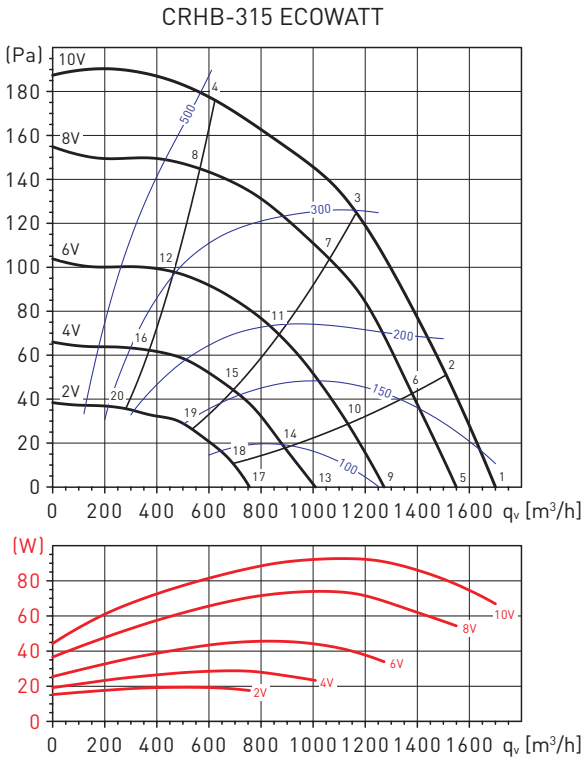

Working point		63	125	250	500	1000	2000	4000	8000	LwA
1	Inlet	38	53	59	61	60	65	69	51	72
	Outlet	39	54	60	65	69	68	69	54	74
2	Inlet	35	53	58	60	59	64	68	50	71
	Outlet	36	54	59	64	68	68	68	53	74
3	Inlet	35	50	56	58	58	65	63	47	69
	Outlet	37	54	58	62	67	68	63	51	72
4	Inlet	36	53	53	57	58	66	57	45	68
	Outlet	39	54	56	61	66	68	59	50	71
5	Inlet	36	50	56	60	58	64	68	47	70
	Outlet	38	51	58	65	66	67	68	50	73
6	Inlet	35	50	55	59	57	64	65	45	69
	Outlet	36	51	57	64	66	67	66	49	72
7	Inlet	36	47	52	58	57	65	56	42	67
	Outlet	37	52	55	61	65	67	57	46	70
8	Inlet	39	47	50	55	57	64	51	39	66
	Outlet	41	49	52	60	64	65	53	43	69
9	Inlet	33	44	52	54	56	66	60	39	68
	Outlet	35	46	53	59	64	67	58	43	70
10	Inlet	34	44	51	53	56	66	53	38	67
	Outlet	36	46	52	57	63	66	53	41	69
11	Inlet	36	41	48	52	57	64	47	36	65
	Outlet	37	47	52	57	63	64	49	39	67
12	Inlet	39	38	45	51	59	59	42	31	62
	Outlet	39	41	47	55	64	58	45	34	66
13	Inlet	29	39	46	52	53	63	42	30	64
	Outlet	31	41	47	55	61	65	45	34	67
14	Inlet	30	39	45	51	53	62	41	29	63
	Outlet	32	42	47	55	61	63	44	32	66
15	Inlet	34	36	43	51	57	58	38	27	61
	Outlet	33	41	45	53	64	56	41	30	65
16	Inlet	33	33	41	50	56	48	33	25	57
	Outlet	33	36	43	52	63	48	36	27	63
17	Inlet	33	33	41	47	55	59	32	24	61
	Outlet	29	35	44	50	60	60	34	25	63
18	Inlet	34	32	40	51	55	56	30	24	59
	Outlet	33	35	44	50	60	55	33	25	62
19	Inlet	35	30	39	48	54	46	28	23	56
	Outlet	32	34	42	50	62	46	31	24	63
20	Inlet	33	29	39	47	53	41	27	23	54
	Outlet	31	33	42	51	62	43	30	24	62

PERFORMANCE CURVES - ACOUSTIC CHARACTERISTICS CRHB ECOWATT

- $q_v$ : Airflow in  $m^3/h$ .
- $p_{st}$ : Static pressure in Pa.
- P: Input power in W.
- SFP: Specific fan power in  $W/m^3/s$  (blue curves).
- Performance data in accordance with ISO 5801 and AMCA 210-99 Standards.

CRHB-355 ECOWATT

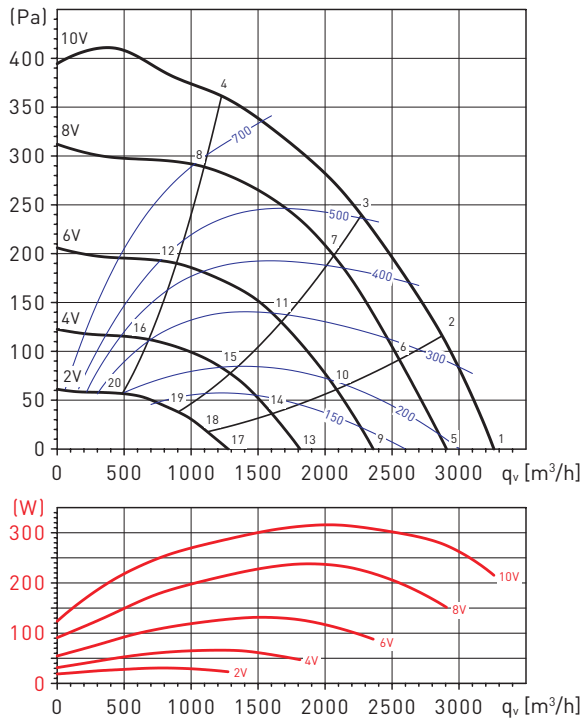

Working point		63	125	250	500	1.000	2.000	4.000	8.000	LwA
1	Inlet	42	56	66	68	69	69	65	71	76
	Outlet	44	59	70	73	76	75	70	75	82
2	Inlet	41	56	64	66	67	68	64	66	74
	Outlet	42	59	68	72	75	73	68	70	79
3	Inlet	39	54	62	64	66	66	62	59	72
	Outlet	41	57	66	70	72	71	65	62	77
4	Inlet	39	61	63	62	64	64	60	54	70
	Outlet	44	65	66	68	70	71	66	60	76
5	Inlet	40	57	63	64	65	66	65	68	73
	Outlet	42	60	66	70	73	72	70	70	78
6	Inlet	39	56	61	62	65	65	61	64	71
	Outlet	41	59	65	69	72	70	65	66	76
7	Inlet	38	54	59	60	63	63	59	57	69
	Outlet	40	57	63	66	69	68	62	59	74
8	Inlet	37	58	59	58	61	61	57	52	67
	Outlet	42	61	62	64	67	68	62	56	73
9	Inlet	38	54	57	59	60	61	67	51	69
	Outlet	40	56	61	64	68	67	69	54	74
10	Inlet	37	52	55	57	59	59	63	48	67
	Outlet	39	56	60	63	66	64	65	51	71
11	Inlet	36	50	54	56	57	57	58	46	64
	Outlet	38	53	58	62	64	61	59	48	68
12	Inlet	37	53	54	53	56	55	53	44	62
	Outlet	44	55	56	59	63	62	56	48	67
13	Inlet	34	46	50	58	53	53	64	39	65
	Outlet	36	49	54	61	61	59	66	43	69
14	Inlet	37	44	49	57	52	51	60	38	63
	Outlet	37	47	54	62	60	57	62	42	67
15	Inlet	34	41	47	55	49	50	52	35	59
	Outlet	36	44	51	60	56	54	54	38	63
16	Inlet	44	43	47	57	49	48	49	35	59
	Outlet	46	45	51	61	57	54	51	38	64
17	Inlet	33	37	42	45	45	61	40	28	61
	Outlet	38	41	46	52	54	61	42	30	63
18	Inlet	32	35	41	43	43	58	37	27	58
	Outlet	35	39	45	50	51	59	40	30	60
19	Inlet	30	35	40	42	41	53	34	26	54
	Outlet	32	38	44	49	48	54	36	28	56
20	Inlet	33	32	37	42	37	43	29	24	47
	Outlet	31	33	41	48	45	43	31	25	51

PERFORMANCE CURVES - ACOUSTIC CHARACTERISTICS CRHB ECOWATT

- $q_v$ : Airflow in  $m^3/h$ .
- $p_{st}$ : Static pressure in Pa.
- P: Input power in W.
- SFP: Specific fan power in  $W/m^3/s$  (blue curves).
- Performance data in accordance with ISO 5801 and AMCA 210-99 Standards.

CRHB-400 ECOWATT

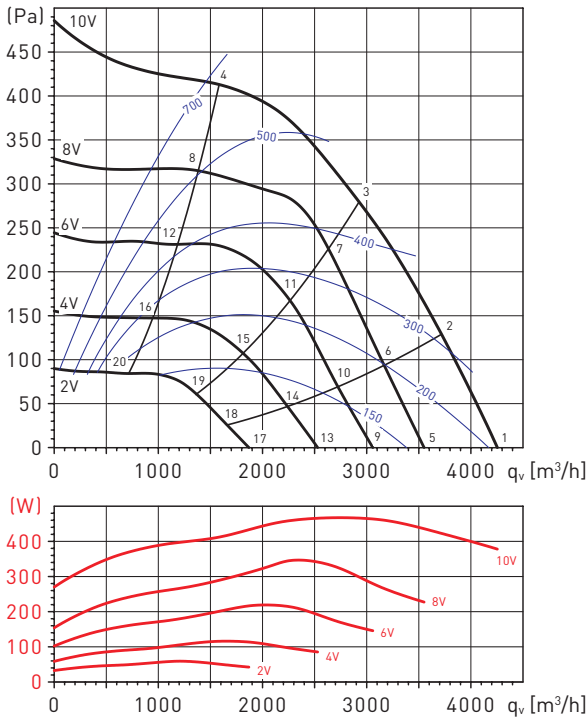

Working point		63	125	250	500	1.000	2.000	4.000	8.000	LwA
1	Inlet	47	70	73	72	69	70	70	73	80
	Outlet	49	73	75	77	78	79	78	77	86
2	Inlet	49	68	70	70	68	68	63	65	76
	Outlet	49	70	73	75	76	77	72	71	82
3	Inlet	46	65	67	68	67	66	60	58	74
	Outlet	45	67	69	72	74	74	68	64	80
4	Inlet	47	67	67	68	67	67	61	55	74
	Outlet	42	64	66	70	74	76	70	64	80
5	Inlet	45	66	68	68	65	67	67	69	76
	Outlet	47	68	71	73	74	76	74	73	82
6	Inlet	45	64	66	67	64	64	59	64	73
	Outlet	46	66	69	71	73	73	67	68	79
7	Inlet	43	60	63	65	65	62	57	57	71
	Outlet	43	63	66	69	72	71	66	63	77
8	Inlet	46	61	63	64	64	62	56	51	70
	Outlet	41	59	62	66	71	71	65	58	76
9	Inlet	43	61	63	63	63	63	69	59	73
	Outlet	45	63	66	68	71	73	72	65	78
10	Inlet	43	58	62	62	62	60	61	58	69
	Outlet	44	61	65	67	69	69	66	62	75
11	Inlet	42	56	59	60	62	58	54	52	67
	Outlet	42	57	62	65	69	66	60	58	72
12	Inlet	44	53	57	58	60	56	51	44	64
	Outlet	42	53	57	62	67	65	58	51	70
13	Inlet	48	53	56	58	57	58	66	45	68
	Outlet	53	55	60	63	66	67	69	53	73
14	Inlet	46	50	55	56	56	52	60	40	64
	Outlet	49	53	58	61	64	61	63	47	69
15	Inlet	47	48	53	56	55	51	54	38	61
	Outlet	47	50	55	60	62	59	57	44	67
16	Inlet	45	46	51	54	54	50	46	36	59
	Outlet	45	47	52	58	62	58	53	42	65
17	Inlet	42	44	48	51	51	59	59	34	63
	Outlet	45	47	52	57	60	62	62	42	67
18	Inlet	40	43	47	50	49	52	57	32	60
	Outlet	44	45	51	56	58	55	60	36	64
19	Inlet	41	42	47	50	48	44	50	31	56
	Outlet	40	42	49	55	55	50	54	34	60
20	Inlet	39	41	46	49	48	43	42	30	54
	Outlet	38	41	47	54	56	51	48	33	60

PERFORMANCE CURVES - ACOUSTIC CHARACTERISTICS CRVB ECOWATT

- $q_v$ : Airflow in  $m^3/h$ .
- $p_{st}$ : Static pressure in Pa.
- P: Input power in W.
- SFP: Specific fan power in  $W/m^3/s$  (blue curves).
- Performance data in accordance with ISO 5801 and AMCA 210-99 Standards.

CRVB-315 ECOWATT

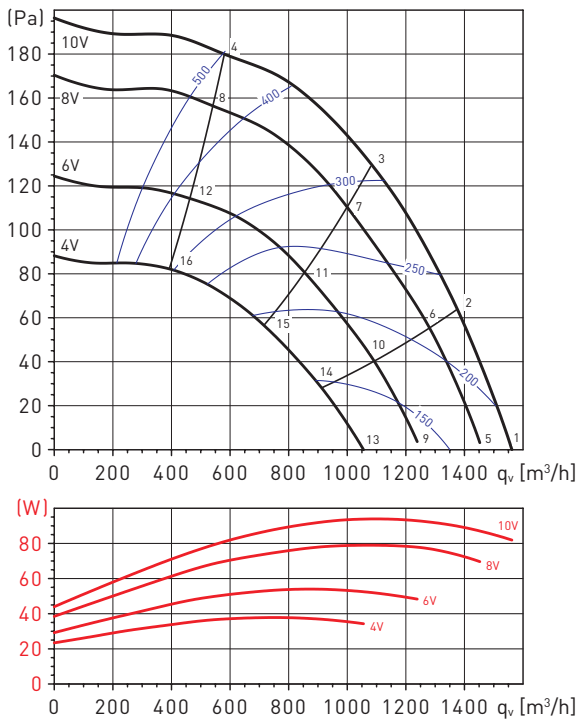

Working point		63	125	250	500	1.000	2.000	4.000	8.000	LwA
1	Inlet	33	50	53	57	56	58	62	46	65
	Outlet	41	56	54	61	64	63	63	47	69
2	Inlet	34	50	52	56	54	56	60	44	64
	Outlet	36	54	53	59	63	62	60	46	67
3	Inlet	36	49	50	54	53	55	59	42	62
	Outlet	35	52	50	58	62	62	58	45	66
4	Inlet	38	51	49	53	53	55	54	42	61
	Outlet	38	51	49	56	62	62	55	45	66
5	Inlet	33	49	51	56	54	56	62	43	64
	Outlet	38	54	53	60	62	62	61	45	68
6	Inlet	34	48	49	54	52	55	61	41	63
	Outlet	35	52	51	59	61	60	58	43	66
7	Inlet	35	46	49	53	52	54	57	40	61
	Outlet	37	50	49	57	60	61	55	43	65
8	Inlet	40	47	48	53	52	54	51	40	59
	Outlet	39	47	48	56	61	61	53	44	65
9	Inlet	33	44	47	53	51	55	58	37	61
	Outlet	35	49	49	55	59	59	58	39	64
10	Inlet	35	41	46	52	49	57	54	35	60
	Outlet	35	46	47	54	57	59	52	37	63
11	Inlet	38	41	45	51	49	56	49	35	59
	Outlet	38	43	45	53	57	61	47	37	63
12	Inlet	41	39	45	50	48	52	44	34	56
	Outlet	42	41	44	52	58	60	46	37	62
13	Inlet	30	38	43	52	48	58	43	31	60
	Outlet	31	42	46	52	55	59	43	32	61
14	Inlet	31	37	41	51	46	58	39	30	59
	Outlet	31	41	45	51	54	59	40	31	61
15	Inlet	34	36	41	51	45	57	39	30	58
	Outlet	34	38	43	50	53	62	40	31	63
16	Inlet	36	35	39	50	44	52	37	29	55
	Outlet	35	36	41	49	53	58	40	31	60

PERFORMANCE CURVES - ACOUSTIC CHARACTERISTICS CRVB ECOWATT

- $q_v$ : Airflow in  $m^3/h$ .
- $p_{st}$ : Static pressure in Pa.
- P: Input power in W.
- SFP: Specific fan power in  $W/m^3/s$  (blue curves).
- Performance data in accordance with ISO 5801 and AMCA 210-99 Standards.

CRVB-355 ECOWATT

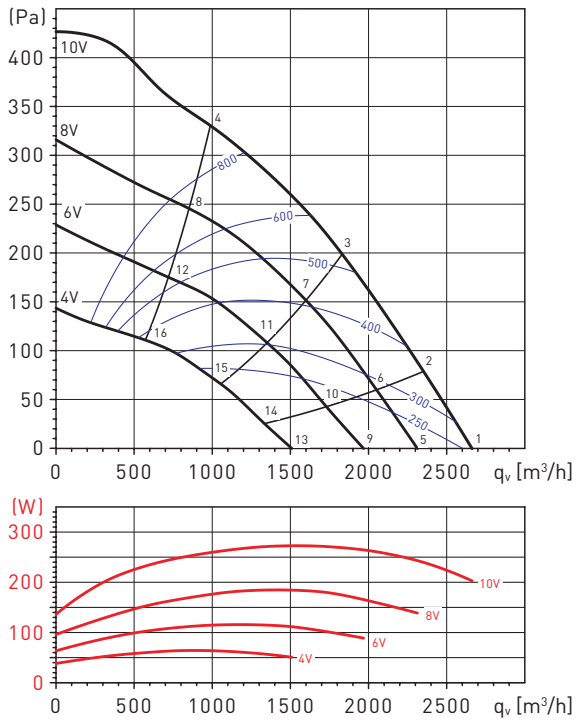

Working point		63	125	250	500	1000	2000	4000	8000	LwA
1	Inlet	45	59	65	68	68	68	62	55	74
	Outlet	47	61	70	74	76	74	67	60	80
2	Inlet	45	60	66	67	66	66	61	54	73
	Outlet	46	61	70	73	75	73	66	59	80
3	Inlet	46	62	65	65	63	64	59	53	71
	Outlet	47	62	69	72	73	72	65	59	78
4	Inlet	48	62	64	65	63	64	60	53	71
	Outlet	47	63	68	71	73	72	67	60	78
5	Inlet	44	57	61	64	64	64	57	50	70
	Outlet	44	59	67	71	72	71	62	55	77
6	Inlet	45	57	61	63	62	62	56	49	69
	Outlet	45	59	67	70	71	69	62	55	76
7	Inlet	46	58	61	61	60	60	55	49	67
	Outlet	46	59	66	69	70	68	61	54	75
8	Inlet	48	58	62	62	61	61	56	50	68
	Outlet	48	59	65	69	71	70	64	57	76
9	Inlet	42	53	57	60	59	59	52	44	65
	Outlet	43	55	63	66	68	66	56	49	72
10	Inlet	43	53	57	59	57	57	50	43	64
	Outlet	43	55	62	65	67	64	56	48	71
11	Inlet	45	53	56	57	55	56	50	42	63
	Outlet	46	55	61	63	65	63	56	48	70
12	Inlet	47	54	58	59	57	57	52	45	65
	Outlet	47	55	62	65	67	65	59	52	72
13	Inlet	40	47	51	57	52	52	44	35	60
	Outlet	41	49	57	61	62	60	48	39	66
14	Inlet	40	47	50	55	50	50	43	33	59
	Outlet	41	50	57	60	60	58	48	38	65
15	Inlet	42	47	50	54	49	49	42	33	58
	Outlet	42	50	55	60	60	56	48	38	64
16	Inlet	42	45	49	54	49	48	42	33	58
	Outlet	43	48	54	59	60	56	49	39	64



PERFORMANCE CURVES - ACOUSTIC CHARACTERISTICS CRVB ECOWATT

- $q_v$ : Airflow in  $m^3/h$ .
- $p_{st}$ : Static pressure in Pa.
- P: Input power in W.
- SFP: Specific fan power in  $W/m^3/s$  (blue curves).
- Performance data in accordance with ISO 5801 and AMCA 210-99 Standards.

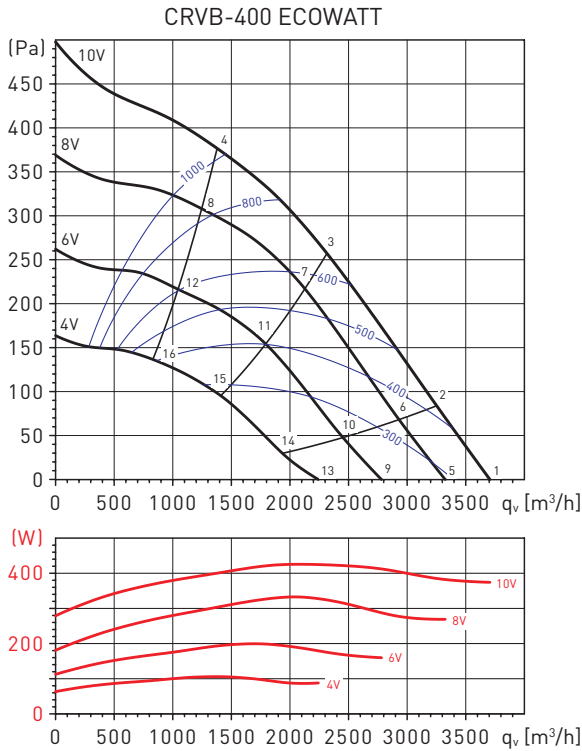

Working point		63	125	250	500	1000	2000	4000	8000	LwA
1	Inlet	50	68	71	70	68	71	69	62	78
	Outlet	51	70	74	77	78	78	76	70	84
2	Inlet	51	67	70	69	67	69	65	58	76
	Outlet	51	67	73	76	77	76	72	66	82
3	Inlet	54	64	69	68	66	67	63	57	75
	Outlet	53	63	70	73	76	75	70	66	81
4	Inlet	57	65	71	70	68	69	65	59	76
	Outlet	57	64	72	75	77	77	73	68	83
5	Inlet	48	65	68	68	65	69	64	58	75
	Outlet	49	66	71	73	75	76	72	66	81
6	Inlet	50	63	67	66	64	66	61	55	73
	Outlet	50	63	69	72	74	73	68	62	79
7	Inlet	53	61	66	65	63	64	60	54	72
	Outlet	53	60	68	71	74	72	67	63	78
8	Inlet	57	63	68	68	65	67	62	57	74
	Outlet	57	61	69	73	75	74	70	65	80
9	Inlet	48	60	64	63	61	64	58	53	70
	Outlet	48	62	67	69	71	72	67	61	77
10	Inlet	48	58	63	62	60	62	55	48	68
	Outlet	49	59	65	68	70	69	63	57	75
11	Inlet	50	56	61	60	59	59	55	48	67
	Outlet	50	56	64	66	70	68	62	57	74
12	Inlet	54	57	63	62	61	61	56	50	69
	Outlet	53	56	65	67	71	69	64	59	75
13	Inlet	47	52	57	57	55	58	50	44	64
	Outlet	54	54	61	63	66	67	60	54	71
14	Inlet	46	51	56	55	54	54	47	40	62
	Outlet	49	52	59	62	64	62	55	48	69
15	Inlet	46	50	55	54	54	53	48	41	61
	Outlet	46	50	57	60	64	61	55	48	68
16	Inlet	47	51	56	56	55	55	49	42	62
	Outlet	47	51	58	62	66	63	57	51	69

DIMENSIONS (mm) CRHB ECOWATT

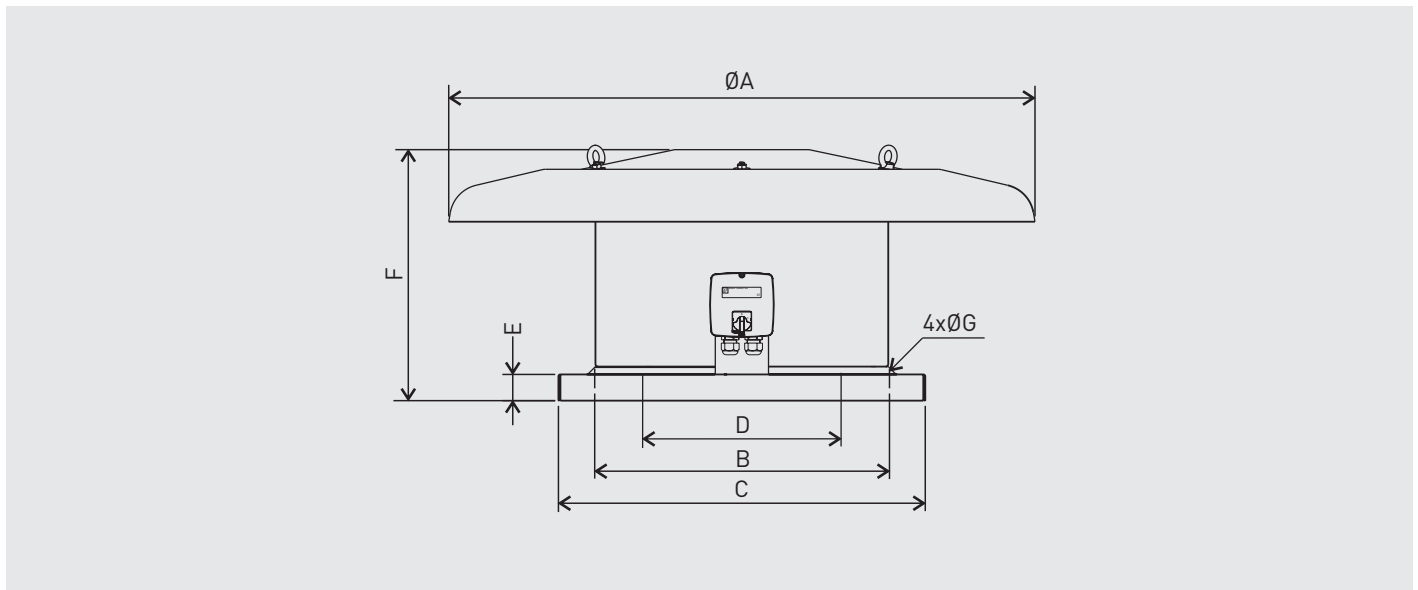

Model	ØA	∅B	∅C	∅D	E	F
315	760	330	435	250	40	333
355	895	450	560	355	40	357
400	895	450	560	355	40	382

INSTALLATION CRHB ECOWATT - MOUNTING ACCESSORIES

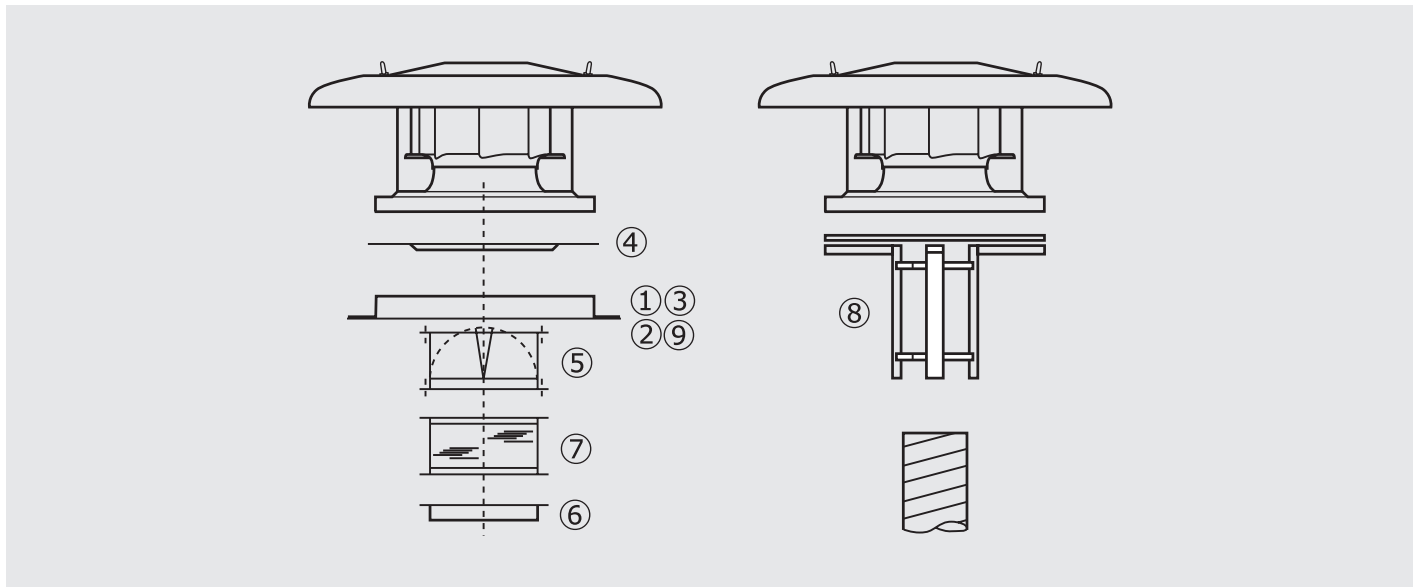

Model of fan	① Sealing frame	② Flat roof insulated up stand	③ Acoustic up stand	④ Accessory adapter plate	⑤ Back draft shutter	⑥ Flange with spigot	⑦ Flexible coupling	⑧ Circular adapter	⑨ Support base for inclined curb mounted installations
315	JMS-435	JBS-435	JAA-435	JPA-435	JCA-435	JBR-43	JAЕ-435	JCC-435	BI-4
355	JBS-560	JBS-560	JAA-560	JPA-560	JCA-560	JBR-560	JAЕ-560	JCC-560	BI-5
400	JBS-560	JBS-560	JAA-560	JPA-560	JCA-560	JBR-560	JAЕ-560	JCC-560	BI-5

DIMENSIONS (mm) CRVB ECOWATT

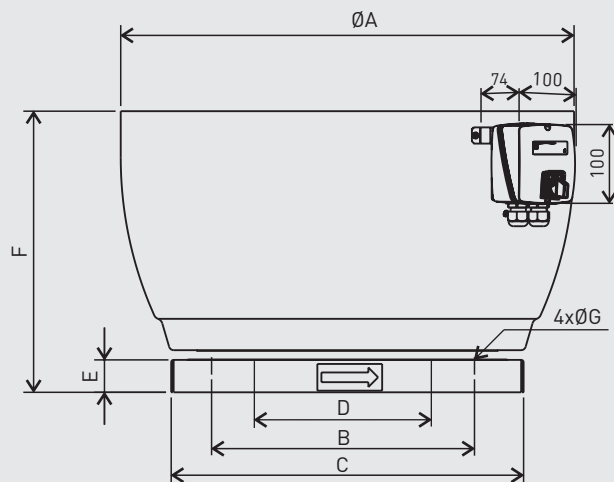

Model	ØA	B	C	D	E	F	ØG
315	560	330	435	250	40	347	12
355	754	450	560	355	40	407	12
400	754	450	560	355	40	407	12

INSTALLATION CRVB ECOWATT - MOUNTING ACCESSORIES

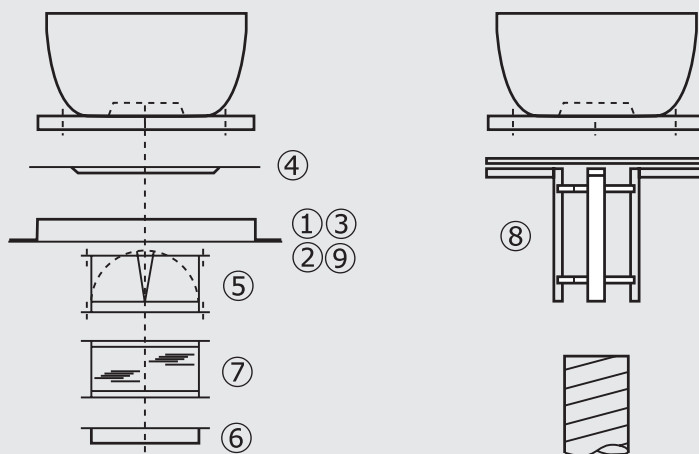

Model of fan	① Sealing frame	② Flat roof insulated up stand	③ Acoustic up stand	④ Accessory adapter plate	⑤ Back draft shutter	⑥ Flange with spigot	⑦ Flexible coupling	⑧ Circular adapter	⑨ Support base for inclined curb mounted installations
315	JMS-435	JBS-435	JAA-435	JPA-435	JCA-435	JBR-435 N	JAE-435 N	JCC-435	BI-4
355	JMS-560	JBS-560	JAA-560	JPA-560	JCA-560 N	JBR-560 N	JAE-560 N	JCC-560	BI-5
400	JMS-560	JBS-560	JAA-560	JPA-560	JCA-560 N	JBR-560 N	JAE-560 N	JCC-560	BI-5

**MOUNTING ACCESSORIES**

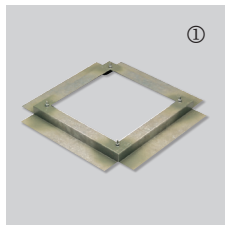

**JMS**  
**Sealing frame**  
- For mounting a roof fan on an up stand or base.  
- Supplied with screws and gasket for a complete weatherproof seal.

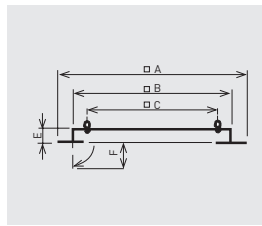

Model	A	B	C	E	F
JMS-435	600	420	330	50	70
JMS-560	725	545	450	50	70

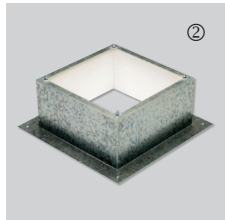

**JBS**  
**Flat roof up stand**  
- For mounting a fan on a flat roof without up stands.  
- For use on horizontal roofs.  
- Internal insulation to prevent condensation.  
- Supplied with screws and gasket for a complete weather seal.

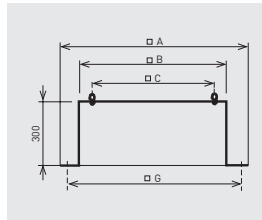

Model	A	B	C	Ø D (M)	E	G
JBS-435	600	419	330	11 (M10)	300	510
JBS-560	725	544	450	11 (M10)	300	635



**JPA**  
**Accessory adapter plate**  
- Used when mounting the accessories (JCA, JBR, JAE).  
- Allows the fan to be disconnected from the upstand without having to remove the duct.

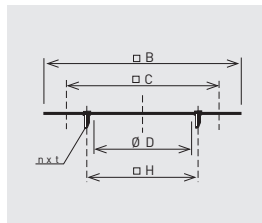

Model	B	C	Ø D	nxt	Ø H
JPA-435	419	330	252	4xM8	280
JPA-560	544	450	358	8xM8	395



**JCA / JCA N**  
**Backdraft shutter**  
- Prevents backdraft when the fan is not operating.  
- To be mounted at the fan inlet with the JPA plate.

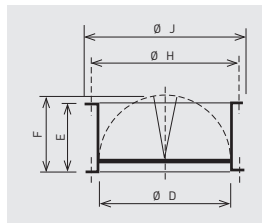

Model	Ø D	E	F	Ø H	Ø J
JCA-435	252	145	174	280	300
JCA-560 N	358	210	227	395	415



**JBR N**  
**Flange**  
- For use when circular connection is required directly to the fan.  
- To be mounted at the fan inlet with the JPA plate or fixed directly to the fan base (rivets or screws not supplied).

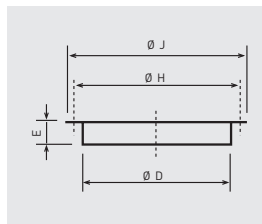

Model	Ø D	E	Ø H	Ø J
JBR-435 N	252	55	280	300
JBR-560 N	358	55	395	415

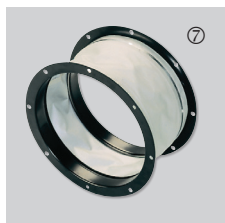

**JAE N**  
**Flexible coupling**  
- Reduces the transmission of vibrations when the duct is connected directly to the fan.  
- To be mounted at the fan inlet with JPA plate.

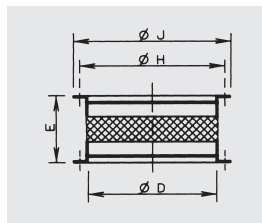

Model	Ø D	E	Ø H	Ø J
JAE-435 N	252	164	280	300
JAE-560 N	358	164	395	415



**JCC N**  
**Adapter for circular duct**  
- For use when fitting the models up to 400, directly to a spirally wound circular duct.

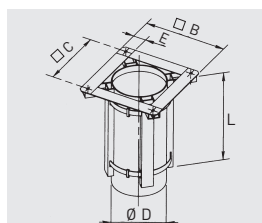

Model	Ø B	Ø C	Ø D	E	L
JCC-435 N	390	330	250	60	350
JCC-560 N	520	450	355	70	350

**MOUNTING ACCESSORIES**

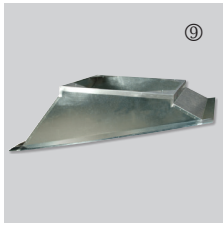

**BI**  
**Support base for inclined curb mounted installations**  
– To ensure a proper installation of the CRHB-CRHT roof fan it is essential to specify the roof pitch angle and the distance between the roof beam profiles.

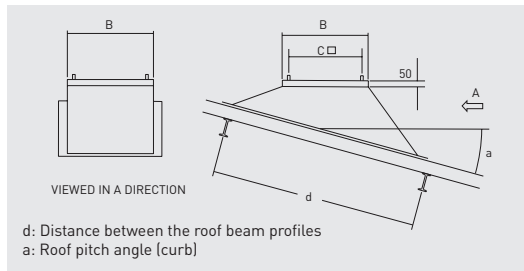

	B	C
BI-4	419	330
BI-5	544	450



**JAA**  
**Acoustic up stand**  
– Reduces in duct and radiated noise.  
– For use when mounting a fan on a flat roof without up stands.  
– Supplied with screws and gasket for a complete weather seal.

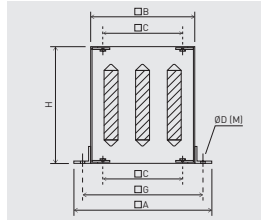

Model	oA	oB	oC	Ø D (M)	H	oG
JAA-435	600	419	330	15 (M12)	750	510
JAA-560	725	545	450	15 (M12)	750	635

Acoustic attenuation in dB(A) at the corresponding frequency band in Hz.

Model	125	250	500	1000	2000	4000	8000
JAA-435	1	7	16	23	25	18	13
JAA-560	2	8	16	29	32	26	17

JAA Attenuator pressure drops.

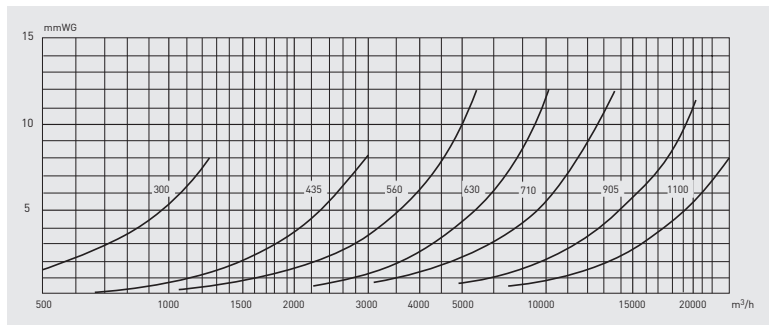

**ELECTRICAL ACCESSORIES**



**CONTROL ECOWATT AC/DC**  
Control element for demand controlled ventilation systems.



**REB-ECOWATT**  
Speed controller for fans fitted with EC motor.



**SC02-A**  
CO<sub>2</sub> and temperature sensor.  
**SC02-AD**  
CO and 2 temperature sensor, with display.  
**SCHT-AD**  
CO<sub>2</sub>, temperature and relative humidity sensor with display.



**TDP-S / TDP-D**  
Pressure sensor.



**CPFL-S / CPFL-E**  
Presence detector.



**BEAS**  
Control module adapting an analogical input signal to monitor ECOWATT fans.