

Designed for wall applications and fitted with a water coil to install in industrial environments.

Characteristics

Can be fitted up to a height of 5 metres.
High performance tangential propeller/impeller giving a low sound level.

Applications

See page BASIC CONCEPTS AIR CURTAINS.

Industrial air curtains fitted with water coils are specially recommended in those environments with a warm water heating system in which its easy to loose heat through open spaces.
Common applications in: entrance goods doors, warehouse doors, halls, drying installations, greenhouses, workshops, etc...

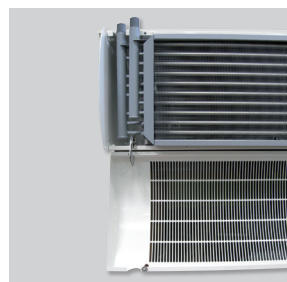

Ease of installation

Fitted with a removable cover up to 180° by means of a set of hinges to ease the wiring.



INSTALLATION HEIGHT

DIMENSIONS (MM)

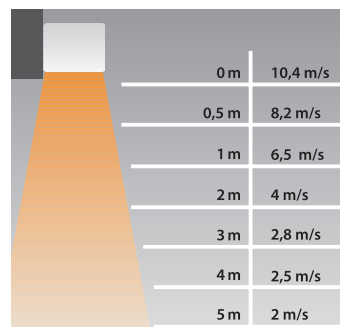
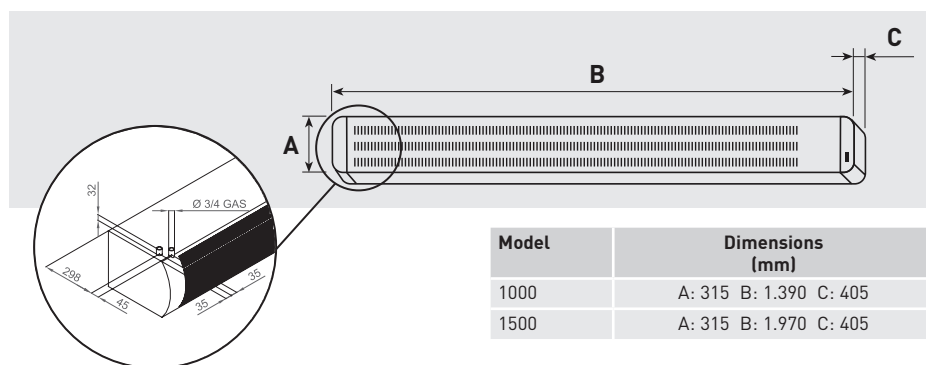

Air distance/speed

ACCESSORIES



CR-20

Each remote control can command up to 5 units in series.
LxWxH (mm): 80x57x120

Speed remote selector	Air curtain model
CR-20	COR-IND M 1000 W 27
CR-20	COR-IND M 1500 W 35

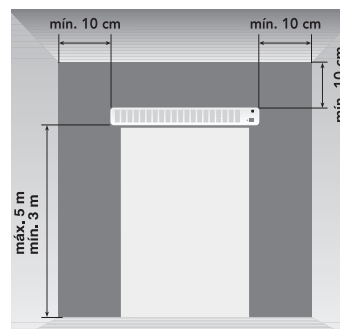

Installation height

TECHNICAL CHARACTERISTICS

Model	Voltage 50Hz (V)	Heat power (kW)*	Motor power (W)	Speeds	Airflow (m³/h)		Outout speed at 0,05 m (m/s)	Maximum ΔT** (°C)		Water flow (l/s)	Threaded water connection	Sound pressure level (dB(A))	Absorbed current (A)	Ambient/ Hot air	Weight (kg)	Colour
					High	Low		High	Low							
					Speed	Speed	Speed	Speed								
COR-IND M 1000 W 27	230	25,5	193	2	3.000	2.700	10	27	29	0,27	3/4"	55	0,90	A/H	40	White RAL 9003
COR-IND M 1500 W 35	230	37,8	245	2	4.100	3.100	9	29	34	0,41	3/4"	59	1,08	A/H	50	White RAL 9003

* Values under the following conditions: water temperature 80°C/60°C, maximum speed; air inlet temperature +15°C.

** Values under the following conditions: water temperature 80°C/60°C, air inlet temperature +15°C.

INPUT TEMPERATURE / WATER OUTPUT 90/70°C			Input air temperature = +15°C				Input air temperature = +20°C			
Model	Fan speed	Airflow (m³/h)	Water pressure drop (kPa)	Water flow (l/s)	Heat power (kW)	Output air temperature (°C)	Water pressure drop (kPa)	Water flow (l/s)	Heat power (kW)	Output air temperature (°C)
COR-IND M 1000 W 27	FAST	3.000	5,96	0,37	30,7	45	5,17	0,34	28,1	48
	SLOW	2.700	5,17	0,34	28,7	46	4,43	0,31	26,3	49
COR-IND M 1500 W 35	FAST	4.100	16,65	0,54	45,1	47	14,12	0,49	41,4	50
	SLOW	3.100	12,24	0,45	37,3	50	10,47	0,41	34,2	53

INPUT TEMPERATURE / WATER OUTPUT 80/60°C			Input air temperature = +15°C				Input air temperature = +20°C			
Model	Fan speed	Airflow (m³/h)	Water pressure drop (kPa)	Water flow (l/s)	Heat power (kW)	Output air temperature (°C)	Water pressure drop (kPa)	Water flow (l/s)	Heat power (kW)	Output air temperature (°C)
COR-IND M 1000 W 27	FAST	3.000	4,19	0,30	25,5	40	3,52	0,27	22,9	43
	SLOW	2.700	3,96	0,29	23,9	41	3,3	0,26	21,4	44
COR-IND M 1500 W 35	FAST	4.100	12,24	0,45	37,8	42	10,47	0,41	34,0	44
	SLOW	3.100	8,82	0,37	31,3	45	7,67	0,34	28,2	47

INPUT TEMPERATURE / WATER OUTPUT 70/50°C			Input air temperature = +15°C				Input air temperature = +20°C			
Model	Fan speed	Airflow (m³/h)	Water pressure drop (kPa)	Water flow (l/s)	Heat power (kW)	Output air temperature (°C)	Water pressure drop (kPa)	Water flow (l/s)	Heat power (kW)	Output air temperature (°C)
COR-IND M 1000 W 27	FAST	3.000	3,21	0,24	20,3	35	2,91	0,21	17,7	38
	SLOW	2.700	3,02	0,24	20,3	36	2,79	0,20	16,5	38
COR-IND M 1500 W 35	FAST	4.100	8,16	0,36	30,4	37	6,9	0,32	26,6	39
	SLOW	3.100	6,16	0,30	25,2	39	4,79	0,26	22,1	41

INPUT TEMPERATURE / WATER OUTPUT 60/40°C			Input air temperature = +15°C				Input air temperature = +20°C			
Model	Fan speed	Airflow (m³/h)	Water pressure drop (kPa)	Water flow (l/s)	Heat power (kW)	Output air temperature (°C)	Water pressure drop (kPa)	Water flow (l/s)	Heat power (kW)	Output air temperature (°C)
COR-IND M 1000 W 27	FAST	3.000	2,61	0,18	14,9	30	2,07	0,15	12,2	32
	SLOW	2.700	2,43	0,17	13,8	30	1,89	0,14	11,3	33
COR-IND M 1500 W 35	FAST	4.100	5,21	0,27	22,8	31	3,76	0,23	19	34
	SLOW	3.100	4,38	0,26	22,1	33	2,85	0,19	15,8	35