



Constructive configuration models from 400 to 800



Constructive configuration models from 900 to 1250

Range of adjustable pitch aerofoil blade, axial flow cabinet fans designed for smoke extraction in fire conditions and certified F400-120 and F300-120 (CE marked).

Fan casing manufactured from heavy gauge galvanised sheet steel internally lined with 25mm thickness fireproof fibreglass acoustic insulation (M0). All models incorporate separate high grade diecast aluminium blades locked within a pressed sheet steel hub.

Motors

Available, depending upon the model:
- with three phase motors in 4 or 6 poles.
- with three phase two speed motors 4/8, 4/6 or 6/12 poles.

F400-120 and F300-120 motors are IP55 class H insulation.

Electrical supplies:

Three phase 220-240/380-415-50 Hz up to 3 kW.

Three phase 380-415V-50Hz, for higher power motors and two speed motors.

(See characteristics chart).

Additional information

Standard air direction: form (A) configuration (motor over impeller). For horizontal airflow installation.

Specific applications



Officially approved to EN12101-3 standard (certificate number 0370-CPD-0420)



Officially approved to EN12101-3 standard (certificate number 0370-CPD-0955)



Car Parks



Motor approved S1 and S2
F400-120 or F300-120 certified motors approved for running continuously (S1) or for emergency operation (S2).



Corrosion resistance
Casings manufactured from galvanised sheet steel. Design enables the casing side panels to be removed and the motor/impeller assembly accessed.



Easy to install
Robust base supports facilitate the installation. (Models from 900 to 1250)



Impeller dynamically balanced
Impeller dynamically balanced, according to ISO 1940 standard, providing vibration free operation.



Wide blade design: higher pressure
Wide blade design to ensure the highest efficient airflow performances.
Configuration 1: models from 400 to 630 (F400) or 800/6 (F300).
Configuration 2: models from 710 (F400) or 800/9 (F300) to 1250.



REFERENCE

C	H	G	T	/	6	-	1	0	0	0	-	6	/	8	/	A	-	1,5	KW
1	2	3	4	5	6	7													

- 1 - : Product range.
- 2 - : Number of poles.
- 3 - : Diameters.
- 4 - : Number of blades.
- 5 - : Blade pitch angle.
- 6 - : Airflow direction.
- 7 - : Motor power.

CHGT 1 SPEED MODELS

TECHNICAL CHARACTERISTICS - F400 - 4 poles - 1450 rpm

Before installation check that the product electrical characteristics listed on the data plate label (voltage, power, frequency, etc.) match those of the intended electrical supply.

Model	Diameter (mm)	Motor power	Full load current at 400V (A)	Weight (kg)	Model	Diameter (mm)	Motor power	Full load current at 400V (A)	Weight (kg)
CHGT/4-400-6/-0,25	400	0,25	0,6	54	CHGT/4-800-6/-1,5	800	1,5	3,17	95
CHGT/4-450-6/-0,25	450	0,25	0,6	57	CHGT/4-800-6/-2,2	800	2,2	4,56	104
CHGT/4-450-6/-0,37	450	0,37	0,87	58	CHGT/4-800-6/-3	800	3	6,15	110
CHGT/4-450-6/-0,55	450	0,55	1,38	58	CHGT/4-800-6/-4	800	4	8,03	116
CHGT/4-500-6/-0,55	500	0,55	1,38	60	CHGT/4-800-6/-5,5	800	5,5	10,4	138
CHGT/4-500-6/-0,75	500	0,75	1,62	65	CHGT/4-800-6/-7,5	800	7,5	13,9	146
CHGT/4-500-6/-1,1	500	1,1	2,35	70	CHGT/4-800-9/-2,2	800	2,2	4,56	107
CHGT/4-560-6/-0,55	560	0,55	1,38	59	CHGT/4-800-9/-3	800	3	6,15	113
CHGT/4-560-6/-0,75	560	0,75	1,62	64	CHGT/4-800-9/-4	800	4	8,03	119
CHGT/4-560-6/-1,1	560	1,1	2,35	69	CHGT/4-800-9/-5,5	800	5,5	10,4	141
CHGT/4-560-6/-1,5	560	1,5	3,17	72	CHGT/4-800-9/-7,5	800	7,5	13,9	149
CHGT/4-560-6/-2,2	560	2,2	4,56	81	CHGT/4-900-3/-2,2	900	2,2	4,56	163
CHGT/4-630-6/-0,75	630	0,75	1,62	68	CHGT/4-900-3/-3	900	3	6,15	169
CHGT/4-630-6/-1,1	630	1,1	2,35	73	CHGT/4-900-3/-4	900	4	8,03	175
CHGT/4-630-6/-1,5	630	1,5	3,17	76	CHGT/4-900-3/-5,5	900	5,5	10,4	197
CHGT/4-630-6/-2,2	630	2,2	4,56	85	CHGT/4-900-3/-7,5	900	7,5	13,9	205
CHGT/4-630-6/-3	630	3	6,15	91	CHGT/4-900-6/-3	900	3	6,15	173
CHGT/4-710-5/-1,1	710	1,1	2,35	85	CHGT/4-900-6/-4	900	4	8,03	179
CHGT/4-710-5/-1,5	710	1,5	3,17	88	CHGT/4-900-6/-5,5	900	5,5	10,4	201
CHGT/4-710-5/-2,2	710	2,2	4,56	97	CHGT/4-900-6/-7,5	900	7,5	13,9	209
CHGT/4-710-5/-3	710	3	6,15	103	CHGT/4-900-6/-11	900	11	20,9	248
CHGT/4-710-5/-4	710	4	8,03	109	CHGT/4-900-9/-5,5	900	5,5	10,4	205
CHGT/4-710-5/-5,5	710	5,5	10,4	131	CHGT/4-900-9/-7,5	900	7,5	13,9	213
CHGT/4-710-7/-1,1	710	1,1	2,35	87	CHGT/4-900-9/-11	900	11	20,9	252
CHGT/4-710-7/-1,5	710	1,5	3,17	90	CHGT/4-900-9/-15	900	15	27,9	274
CHGT/4-710-7/-2,2	710	2,2	4,56	99	CHGT/4-1000-3/-3	1000	3	6,15	166
CHGT/4-710-7/-3	710	3	6,15	105	CHGT/4-1000-3/-4	1000	4	8,03	172
CHGT/4-710-7/-4	710	4	8,03	111	CHGT/4-1000-3/-5,5	1000	5,5	10,4	194
CHGT/4-710-7/-5,5	710	5,5	10,4	133	CHGT/4-1000-3/-7,5	1000	7,5	13,9	202
CHGT/4-800-3/-1,1	800	1,1	2,35	88	CHGT/4-1000-3/-11	1000	11	20,9	241
CHGT/4-800-3/-1,5	800	1,5	3,17	91	CHGT/4-1000-6/-4	1000	4	8,03	177
CHGT/4-800-3/-2,2	800	2,2	4,56	100	CHGT/4-1000-6/-5,5	1000	5,5	10,4	199
CHGT/4-800-3/-3	800	3	6,15	106	CHGT/4-1000-6/-7,5	1000	7,5	13,9	207
CHGT/4-800-3/-4	800	4	8,03	112	CHGT/4-1000-6/-11	1000	11	20,9	246
CHGT/4-800-3/-5,5	800	5,5	10,4	134	CHGT/4-1000-6/-15	1000	15	27,9	268
					CHGT/4-1000-6/-18,5	1000	18,5	35,1	301

TECHNICAL CHARACTERISTICS - **F400** - 4 poles - 1450 rpm (CONTINUATION)

Model	Diameter (mm)	Motor power	Full load current at 400V (A)	Weight (kg)
CHGT/4-1000-9/-7,5	1000	7,5	13,9	212
CHGT/4-1000-9/-11	1000	11	20,9	251
CHGT/4-1000-9/-15	1000	15	27,9	273
CHGT/4-1000-9/-18,5	1000	18,5	35,1	306
CHGT/4-1000-9/-22	1000	22	41	323
CHGT/4-1250-3/-7,5	1250	7,5	13,9	359
CHGT/4-1250-3/-11	1250	11	20,9	398
CHGT/4-1250-3/-15	1250	15	27,9	420
CHGT/4-1250-3/-18,5	1250	18,5	35,1	453
CHGT/4-1250-3/-22	1250	22	41	470
CHGT/4-1250-3/-30	1250	30	57,1	513

Model	Diameter (mm)	Motor power	Full load current at 400V (A)	Weight (kg)
CHGT/4-1250-6/-15	1250	15	27,9	425
CHGT/4-1250-6/-18,5	1250	18,5	35,1	458
CHGT/4-1250-6/-22	1250	22	41	475
CHGT/4-1250-6/-30	1250	30	57,1	518
CHGT/4-1250-6/-37	1250	37	66,8	655
CHGT/4-1250-6/-45	1250	45	80,9	690
CHGT/4-1250-9/-15	1250	15	27,9	430
CHGT/4-1250-9/-18,5	1250	18,5	35,1	463
CHGT/4-1250-9/-22	1250	22	41	480
CHGT/4-1250-9/-30	1250	30	57,1	523
CHGT/4-1250-9/-37	1250	37	66,8	660
CHGT/4-1250-9/-45	1250	45	80,9	695

TECHNICAL CHARACTERISTICS - **F400** - 6 poles - 950 rpm

Model	Diameter (mm)	Motor power	Full load current at 400V (A)	Weight (kg)
CHGT/6-560-6/-0,55	560	0,55	1,62	65
CHGT/6-630-6/-0,55	630	0,55	1,62	69
CHGT/6-630-6/-0,75	630	0,75	1,93	75
CHGT/6-630-6/-1,1	630	1,1	2,69	82
CHGT/6-710-5/-0,55	710	0,55	1,62	81
CHGT/6-710-5/-0,75	710	0,75	1,93	87
CHGT/6-710-5/-1,1	710	1,1	2,69	94
CHGT/6-710-7/-0,55	710	0,55	1,62	83
CHGT/6-710-7/-0,75	710	0,75	1,93	89
CHGT/6-710-7/-1,1	710	1,1	2,69	96
CHGT/6-800-3/-0,75	800	0,75	1,93	90
CHGT/6-800-3/-1,1	800	1,1	2,69	97
CHGT/6-800-3/-1,5	800	1,5	3,7	100
CHGT/6-800-6/-0,75	800	0,75	1,93	94
CHGT/6-800-6/-1,1	800	1,1	2,69	101
CHGT/6-800-6/-1,5	800	1,5	3,7	104
CHGT/6-800-6/-2,2	800	2,2	5,22	118
CHGT/6-800-9/-0,75	800	0,75	1,93	97
CHGT/6-800-9/-1,1	800	1,1	2,69	104
CHGT/6-800-9/-1,5	800	1,5	3,7	107
CHGT/6-800-9/-2,2	800	2,2	5,22	121
CHGT/6-800-9/-3	800	3	6,91	140

Model	Diameter (mm)	Motor power	Full load current at 400V (A)	Weight (kg)
CHGT/6-900-3/-1,5	900	1,5	3,7	163
CHGT/6-900-3/-2,2	900	2,2	5,22	177
CHGT/6-900-6/-1,5	900	1,5	3,7	167
CHGT/6-900-6/-2,2	900	2,2	5,22	181
CHGT/6-900-6/-3	900	3	6,91	200
CHGT/6-900-9/-1,5	900	1,5	3,7	171
CHGT/6-900-9/-2,2	900	2,2	5,22	185
CHGT/6-900-9/-3	900	3	6,91	204
CHGT/6-900-9/-5,5	900	5,5	12,9	217
CHGT/6-1000-3/-1,5	1000	1,5	3,7	160
CHGT/6-1000-3/-2,2	1000	2,2	5,22	174
CHGT/6-1000-3/-3	1000	3	6,91	193
CHGT/6-1000-3/-4	1000	4	9,11	198
CHGT/6-1000-6/-1,5	1000	1,5	3,7	165
CHGT/6-1000-6/-2,2	1000	2,2	5,22	179
CHGT/6-1000-6/-3	1000	3	6,91	198
CHGT/6-1000-6/-4	1000	4	9,11	203
CHGT/6-1000-6/-5,5	1000	5,5	12,9	211
CHGT/6-1000-9/-2,2	1000	2,2	5,22	184
CHGT/6-1000-9/-3	1000	3	6,91	203
CHGT/6-1000-9/-4	1000	4	9,11	208
CHGT/6-1000-9/-5,5	1000	5,5	12,9	216
CHGT/6-1000-9/-7,5	1000	7,5	14,8	256

TECHNICAL CHARACTERISTICS - F400 - 6 poles - 950 rpm (CONTINUATION)

Model	Diameter (mm)	Motor power	Full load current at 400V (A)	Weight (kg)
CHGT/6-1250-3/-2,2	1250	2,2	5,22	331
CHGT/6-1250-3/-3	1250	3	6,91	350
CHGT/6-1250-3/-4	1250	4	9,11	355
CHGT/6-1250-3/-5,5	1250	5,5	12,9	363
CHGT/6-1250-3/-7,5	1250	7,5	14,8	403
CHGT/6-1250-3/-11	1250	11	21,9	425

Model	Diameter (mm)	Motor power	Full load current at 400V (A)	Weight (kg)
CHGT/6-1250-9/-5,5	1250	5,5	12,9	373
CHGT/6-1250-9/-7,5	1250	7,5	14,8	413
CHGT/6-1250-9/-11	1250	11	21,9	435
CHGT/6-1250-9/-15	1250	15	28,2	480
CHGT/6-1250-9/-18,5	1250	18,5	35,9	510
CHGT/6-1250-9/-22	1250	22	42,4	520

CHGT/6-1250-6/-4	1250	4	9,11	360
CHGT/6-1250-6/-5,5	1250	5,5	12,9	368
CHGT/6-1250-6/-7,5	1250	7,5	14,8	408
CHGT/6-1250-6/-11	1250	11	21,9	430
CHGT/6-1250-6/-15	1250	15	28,2	475

TECHNICAL CHARACTERISTICS - F400 - 4/8 poles - 1450/730 rpm

Model	Diameter (mm)	Motor power		Full load current 400V (A)		Weight (kg)
		HS	LS	HS	LS	

CHGT/4/8-400-6/-0,55/0,09	400	0,55	0,09	1,7	0,837	60
---------------------------	-----	------	------	-----	-------	----

CHGT/4/8-450-6/-0,55/0,09	450	0,55	0,09	1,7	0,837	63
---------------------------	-----	------	------	-----	-------	----

CHGT/4/8-500-6/-0,55/0,09	500	0,55	0,09	1,7	0,837	65
---------------------------	-----	------	------	-----	-------	----

CHGT/4/8-500-6/-0,75/0,12	500	0,75	0,12	1,86	0,833	65
---------------------------	-----	------	------	------	-------	----

CHGT/4/8-500-6/-1,1/0,18	500	1,1	0,18	2,73	1,21	77
--------------------------	-----	-----	------	------	------	----

CHGT/4/8-560-6/-0,55/0,09	560	0,55	0,09	1,7	0,837	64
---------------------------	-----	------	------	-----	-------	----

CHGT/4/8-560-6/-0,75/0,12	560	0,75	0,12	1,86	0,833	64
---------------------------	-----	------	------	------	-------	----

CHGT/4/8-560-6/-1,1/0,18	560	1,1	0,18	2,73	1,21	76
--------------------------	-----	-----	------	------	------	----

CHGT/4/8-560-6/-1,5/0,25	560	1,5	0,25	3,65	1,6	79
--------------------------	-----	-----	------	------	-----	----

CHGT/4/8-560-6/-2,2/0,37	560	2,2	0,37	4,7	1,66	87
--------------------------	-----	-----	------	-----	------	----

CHGT/4/8-630-6/-0,55/0,09	630	0,55	0,09	1,7	0,837	68
---------------------------	-----	------	------	-----	-------	----

CHGT/4/8-630-6/-0,75/0,12	630	0,75	0,12	1,86	0,833	68
---------------------------	-----	------	------	------	-------	----

CHGT/4/8-630-6/-1,1/0,18	630	1,1	0,18	2,73	1,21	80
--------------------------	-----	-----	------	------	------	----

CHGT/4/8-630-6/-1,5/0,25	630	1,5	0,25	3,65	1,6	83
--------------------------	-----	-----	------	------	-----	----

CHGT/4/8-630-6/-2,2/0,37	630	2,2	0,37	4,7	1,66	91
--------------------------	-----	-----	------	-----	------	----

CHGT/4/8-630-6/-3/0,55	630	3	0,55	6,29	2,35	92
------------------------	-----	---	------	------	------	----

CHGT/4/8-630-6/-4/0,75	630	4	0,75	8,44	2,25	99
------------------------	-----	---	------	------	------	----

CHGT/4/8-710-5/-0,75/0,12	710	0,75	0,12	1,86	0,833	80
---------------------------	-----	------	------	------	-------	----

CHGT/4/8-710-5/-1,1/0,18	710	1,1	0,18	2,73	1,21	92
--------------------------	-----	-----	------	------	------	----

CHGT/4/8-710-5/-1,5/0,25	710	1,5	0,25	3,65	1,6	95
--------------------------	-----	-----	------	------	-----	----

CHGT/4/8-710-5/-2,2/0,37	710	2,2	0,37	4,7	1,66	103
--------------------------	-----	-----	------	-----	------	-----

CHGT/4/8-710-5/-3/0,55	710	3	0,55	6,29	2,35	104
------------------------	-----	---	------	------	------	-----

CHGT/4/8-710-5/-4/0,75	710	4	0,75	8,44	2,25	111
------------------------	-----	---	------	------	------	-----

CHGT/4/8-710-5/-5,5/1,1	710	5,5	1,1	11,7	3,7	133
-------------------------	-----	-----	-----	------	-----	-----

Model	Diameter (mm)	Motor power		Full load current 400V (A)		Weight (kg)
		HS	LS	HS	LS	

CHGT/4/8-710-7/-1,1/0,18	710	1,1	0,18	2,73	1,21	94
--------------------------	-----	-----	------	------	------	----

CHGT/4/8-710-7/-1,5/0,25	710	1,5	0,25	3,65	1,6	97
--------------------------	-----	-----	------	------	-----	----

CHGT/4/8-710-7/-2,2/0,37	710	2,2	0,37	4,7	1,66	105
--------------------------	-----	-----	------	-----	------	-----

CHGT/4/8-710-7/-3/0,55	710	3	0,55	6,29	2,35	106
------------------------	-----	---	------	------	------	-----

CHGT/4/8-710-7/-4/0,75	710	4	0,75	8,44	2,25	113
------------------------	-----	---	------	------	------	-----

CHGT/4/8-710-7/-5,5/1,1	710	5,5	1,1	11,7	3,7	135
-------------------------	-----	-----	-----	------	-----	-----

CHGT/4/8-800-3/-1,1/0,18	800	1,1	0,18	2,73	1,21	95
--------------------------	-----	-----	------	------	------	----

CHGT/4/8-800-3/-1,5/0,25	800	1,5	0,25	3,65	1,6	98
--------------------------	-----	-----	------	------	-----	----

CHGT/4/8-800-3/-2,2/0,37	800	2,2	0,37	4,7	1,66	106
--------------------------	-----	-----	------	-----	------	-----

CHGT/4/8-800-3/-3/0,55	800	3	0,55	6,29	2,35	107
------------------------	-----	---	------	------	------	-----

CHGT/4/8-800-3/-4/0,75	800	4	0,75	8,44	2,25	114
------------------------	-----	---	------	------	------	-----

CHGT/4/8-800-6/-1,5/0,25	800	1,5	0,25	3,65	1,6	102
--------------------------	-----	-----	------	------	-----	-----

CHGT/4/8-800-6/-2,2/0,37	800	2,2	0,37	4,7	1,66	110
--------------------------	-----	-----	------	-----	------	-----

CHGT/4/8-800-6/-3/0,55	800	3	0,55	6,29	2,35	111
------------------------	-----	---	------	------	------	-----

CHGT/4/8-800-6/-4/0,75	800	4	0,75	8,44	2,25	118
------------------------	-----	---	------	------	------	-----

CHGT/4/8-800-6/-5,5/1,1	800	5,5	1,1	11,7	3,7	140
-------------------------	-----	-----	-----	------	-----	-----

CHGT/4/8-800-6/-7,5/1,5	800	7,5	1,5	15,9	4,72	153
-------------------------	-----	-----	-----	------	------	-----

CHGT/4/8-800-9/-2,2/0,37	800	2,2	0,37	4,7	1,66	113
--------------------------	-----	-----	------	-----	------	-----

CHGT/4/8-800-9/-3/0,55	800	3	0,55	6,29	2,35	114
------------------------	-----	---	------	------	------	-----

CHGT/4/8-800-9/-4/0,75	800	4	0,75	8,44	2,25	121
------------------------	-----	---	------	------	------	-----

CHGT/4/8-800-9/-5,5/1,1	800	5,5	1,1	11,7	3,7	143
-------------------------	-----	-----	-----	------	-----	-----

CHGT/4/8-800-9/-7,5/1,5	800	7,5	1,5	15,9	4,72	156
-------------------------	-----	-----	-----	------	------	-----

TECHNICAL CHARACTERISTICS - F400 - 4/8 poles - 1450/730 rpm (CONTINUATION)

Model	Diameter (mm)	Motor power		Full load current 400V (A)		Weight (kg)
		HS	LS	HS	LS	
CHGT/4/8-900-3/-2,2/0,37	900	2,2	0,37	4,7	1,66	169
CHGT/4/8-900-3/-3/0,55	900	3	0,55	6,29	2,35	170
CHGT/4/8-900-3/-4/0,75	900	4	0,75	8,44	2,25	177
CHGT/4/8-900-3/-5,5/1,1	900	5,5	1,1	11,7	3,7	199
CHGT/4/8-900-3/-7,5/1,5	900	7,5	1,5	15,9	4,72	212
CHGT/4/8-900-6/-2,2/0,37	900	2,2	0,37	4,7	1,66	173
CHGT/4/8-900-6/-3/0,55	900	3	0,55	6,29	2,35	174
CHGT/4/8-900-6/-4/0,75	900	4	0,75	8,44	2,25	181
CHGT/4/8-900-6/-5,5/1,1	900	5,5	1,1	11,7	3,7	203
CHGT/4/8-900-6/-7,5/1,5	900	7,5	1,5	15,9	4,72	216
CHGT/4/8-900-6/-11/3	900	11	3	21	7	247
CHGT/4/8-900-9/-4/0,75	900	4	0,75	8,44	2,25	185
CHGT/4/8-900-9/-5,5/1,1	900	5,5	1,1	11,7	3,7	207
CHGT/4/8-900-9/-7,5/1,5	900	7,5	1,5	15,9	4,72	220
CHGT/4/8-900-9/-11/3	900	11	3	21	7	251
CHGT/4/8-900-9/-14/3,5	900	14	3,5	26,5	8,45	270
CHGT/4/8-1000-3/-2,2/0,37	1000	2,2	0,37	4,7	1,66	166
CHGT/4/8-1000-3/-3/0,55	1000	3	0,55	6,29	2,35	167
CHGT/4/8-1000-3/-4/0,75	1000	4	0,75	8,44	2,25	174
CHGT/4/8-1000-3/-5,5/1,1	1000	5,5	1,1	11,7	3,7	196
CHGT/4/8-1000-3/-7,5/1,5	1000	7,5	1,5	15,9	4,72	209
CHGT/4/8-1000-3/-11/3	1000	11	3	21	7	240
CHGT/4/8-1000-6/-4/0,75	1000	4	0,75	8,44	2,25	179
CHGT/4/8-1000-6/-5,5/1,1	1000	5,5	1,1	11,7	3,7	201
CHGT/4/8-1000-6/-7,5/1,5	1000	7,5	1,5	15,9	4,72	214
CHGT/4/8-1000-6/-11/3	1000	11	3	21	7	245
CHGT/4/8-1000-6/-14/3,5	1000	14	3,5	26,5	8,45	264
CHGT/4/8-1000-6/-17/4,3	1000	17	4,3	33,4	12,7	295
CHGT/4/8-1000-6/-20/5	1000	20	5	38,6	14,1	310

Model	Diameter (mm)	Motor power		Full load current 400V (A)		Weight (kg)
		HS	LS	HS	LS	
CHGT/4/8-1000-9/-5,5/1,1	1000	5,5	1,1	11,7	3,7	206
CHGT/4/8-1000-9/-7,5/1,5	1000	7,5	1,5	15,9	4,72	219
CHGT/4/8-1000-9/-11/3	1000	11	3	21	7	250
CHGT/4/8-1000-9/-14/3,5	1000	14	3,5	26,5	8,45	269
CHGT/4/8-1000-9/-17/4,3	1000	17	4,3	33,4	12,7	300
CHGT/4/8-1000-9/-20/5	1000	20	5	38,6	14,1	315
CHGT/4/8-1250-3/-5,5/1,1	1250	5,5	1,1	11,7	3,7	353
CHGT/4/8-1250-3/-7,5/1,5	1250	7,5	1,5	15,9	4,72	366
CHGT/4/8-1250-3/-11/3	1250	11	3	21	7	397
CHGT/4/8-1250-3/-14/3,5	1250	14	3,5	26,5	8,45	416
CHGT/4/8-1250-3/-17/4,3	1250	17	4,3	33,4	12,7	447
CHGT/4/8-1250-3/-20/5	1250	20	5	38,6	14,1	462
CHGT/4/8-1250-3/-28/6,5	1250	28	6,5	52	18	520
CHGT/4/8-1250-6/-11/3	1250	11	3	21	7	402
CHGT/4/8-1250-6/-14/3,5	1250	14	3,5	26,5	8,45	421
CHGT/4/8-1250-6/-17/4,3	1250	17	4,3	33,4	12,7	452
CHGT/4/8-1250-6/-20/5	1250	20	5	38,6	14,1	467
CHGT/4/8-1250-6/-28/6,5	1250	28	6,5	52	18	525
CHGT/4/8-1250-6/-30/8	1250	30	8	56,5	21,8	555
CHGT/4/8-1250-6/-37/9,2	1250	37	9,2	74,2	25,4	658
CHGT/4/8-1250-6/-44/11	1250	44	11	80,2	27,2	715
CHGT/4/8-1250-9/-14/3,5	1250	14	3,5	26,5	8,45	426
CHGT/4/8-1250-9/-17/4,3	1250	17	4,3	33,4	12,7	457
CHGT/4/8-1250-9/-20/5	1250	20	5	38,6	14,1	472
CHGT/4/8-1250-9/-28/6,5	1250	28	6,5	52	18	530
CHGT/4/8-1250-9/-30/8	1250	30	8	56,5	21,8	560
CHGT/4/8-1250-9/-37/9,2	1250	37	9,2	74,2	25,4	663
CHGT/4/8-1250-9/-44/11	1250	44	11	80,2	27,2	720

TECHNICAL CHARACTERISTICS - F400 - 4/6 poles - 1450/950 rpm

Model	Diameter (mm)	Motor power		Full load current 400V (A)		Weight (kg)
		HS	LS	HS	LS	
CHGT/4/6-400-6/-0,55/0,2	400	0,55	0,2	1,75	1,05	56
CHGT/4/6-450-6/-0,55/0,2	450	0,55	0,2	1,75	1,05	59

Model	Diameter (mm)	Motor power		Full load current 400V (A)		Weight (kg)
		HS	LS	HS	LS	
CHGT/4/6-500-6/-0,55/0,2	500	0,55	0,2	1,75	1,05	61
CHGT/4/6-500-6/-0,75/0,25	500	0,75	0,25	1,94	1,32	62
CHGT/4/6-500-6/-1,1/0,3	500	1,1	0,3	2,84	1,49	66

TECHNICAL CHARACTERISTICS - F400 - 4/6 poles - 1450/950 rpm (CONTINUATION)

Model	Diameter (mm)	Motor power		Full load current 400V (A)		Weight (kg)
		HS	LS	HS	LS	
CHGT/4/6-560-6/-0,55/0,2	560	0,55	0,2	1,75	1,05	60
CHGT/4/6-560-6/-0,75/0,25	560	0,75	0,25	1,94	1,32	61
CHGT/4/6-560-6/-1,1/0,3	560	1,1	0,3	2,84	1,49	65
CHGT/4/6-560-6/-1,5/0,37	560	1,5	0,37	3,65	1,62	69
CHGT/4/6-630-6/-0,55/0,2	630	0,55	0,2	1,75	1,05	64
CHGT/4/6-630-6/-0,75/0,25	630	0,75	0,25	1,94	1,32	65
CHGT/4/6-630-6/-1,1/0,3	630	1,1	0,3	2,84	1,49	69
CHGT/4/6-630-6/-1,5/0,37	630	1,5	0,37	3,65	1,62	73
CHGT/4/6-630-6/-2,2/0,7	630	2,2	0,7	4,91	2,48	80
CHGT/4/6-630-6/-3/1	630	3	1	6,85	3,86	89
CHGT/4/6-710-5/-0,75/0,25	710	0,75	0,25	1,94	1,32	77
CHGT/4/6-710-5/-1,1/0,3	710	1,1	0,3	2,84	1,49	81
CHGT/4/6-710-5/-1,5/0,37	710	1,5	0,37	3,65	1,62	85
CHGT/4/6-710-5/-2,2/0,7	710	2,2	0,7	4,91	2,48	92
CHGT/4/6-710-5/-3/1	710	3	1	6,85	3,86	101
CHGT/4/6-710-5/-4,5/1,5	710	4,5	1,5	10,2	5,38	133
CHGT/4/6-710-5/-6/2,2	710	6	2,2	13,7	6,96	144
CHGT/4/6-710-7/-1,1/0,3	710	1,1	0,3	2,84	1,49	83
CHGT/4/6-710-7/-1,5/0,37	710	1,5	0,37	3,65	1,62	87
CHGT/4/6-710-7/-2,2/0,7	710	2,2	0,7	4,91	2,48	94
CHGT/4/6-710-7/-3/1	710	3	1	6,85	3,86	103
CHGT/4/6-710-7/-4,5/1,5	710	4,5	1,5	10,2	5,38	135
CHGT/4/6-710-7/-6/2,2	710	6	2,2	13,7	6,96	146
CHGT/4/6-800-3/-1,1/0,3	800	1,1	0,3	2,84	1,49	84
CHGT/4/6-800-3/-1,5/0,37	800	1,5	0,37	3,65	1,62	88
CHGT/4/6-800-3/-2,2/0,7	800	2,2	0,7	4,91	2,48	95
CHGT/4/6-800-3/-3/1	800	3	1	6,85	3,86	104
CHGT/4/6-800-3/-4,5/1,5	800	4,5	1,5	10,2	5,38	136
CHGT/4/6-800-3/-6/2,2	800	6	2,2	13,7	6,96	147
CHGT/4/6-800-6/-1,5/0,37	800	1,5	0,37	3,65	1,62	92
CHGT/4/6-800-6/-2,2/0,7	800	2,2	0,7	4,91	2,48	99
CHGT/4/6-800-6/-3/1	800	3	1	6,85	3,86	108
CHGT/4/6-800-6/-4,5/1,5	800	4,5	1,5	10,2	5,38	140
CHGT/4/6-800-6/-6/2,2	800	6	2,2	13,7	6,96	151
CHGT/4/6-800-9/-2,2/0,7	800	2,2	0,7	4,91	2,48	102
CHGT/4/6-800-9/-3/1	800	3	1	6,85	3,86	111
CHGT/4/6-800-9/-4,5/1,5	800	4,5	1,5	10,2	5,38	143
CHGT/4/6-800-9/-6/2,2	800	6	2,2	13,7	6,96	154

Model	Diameter (mm)	Motor power		Full load current 400V (A)		Weight (kg)
		HS	LS	HS	LS	
CHGT/4/6-900-3/-2,2/0,7	900	2,2	0,7	4,91	2,48	158
CHGT/4/6-900-3/-3/1	900	3	1	6,85	3,86	167
CHGT/4/6-900-3/-4,5/1,5	900	4,5	1,5	10,2	5,38	199
CHGT/4/6-900-3/-6/2,2	900	6	2,2	13,7	6,96	210
CHGT/4/6-900-3/-10/3,3	900	10	3,3	22	8,74	251
CHGT/4/6-900-6/-2,2/0,7	900	2,2	0,7	4,91	2,48	162
CHGT/4/6-900-6/-3/1	900	3	1	6,85	3,86	171
CHGT/4/6-900-6/-4,5/1,5	900	4,5	1,5	10,2	5,38	203
CHGT/4/6-900-6/-6/2,2	900	6	2,2	13,7	6,96	214
CHGT/4/6-900-6/-10/3,3	900	10	3,3	22	8,74	255
CHGT/4/6-900-6/-14/4,5	900	14	4,5	29,5	11,2	270
CHGT/4/6-900-9/-4,5/1,5	900	4,5	1,5	10,2	5,38	207
CHGT/4/6-900-9/-6/2,2	900	6	2,2	13,7	6,96	218
CHGT/4/6-900-9/-10/3,3	900	10	3,3	22	8,74	259
CHGT/4/6-900-9/-14/4,5	900	14	4,5	29,5	11,2	274
CHGT/4/6-1000-3/-2,2/0,7	1000	2,2	0,7	4,91	2,48	155
CHGT/4/6-1000-3/-3/1	1000	3	1	6,85	3,86	164
CHGT/4/6-1000-3/-4,5/1,5	1000	4,5	1,5	10,2	5,38	196
CHGT/4/6-1000-3/-6/2,2	1000	6	2,2	13,7	6,96	207
CHGT/4/6-1000-3/-10/3,3	1000	10	3,3	22	8,74	248
CHGT/4/6-1000-3/-14/4,5	1000	14	4,5	29,5	11,2	263
CHGT/4/6-1000-6/-4,5/1,5	1000	4,5	1,5	10,2	5,38	201
CHGT/4/6-1000-6/-6/2,2	1000	6	2,2	13,7	6,96	212
CHGT/4/6-1000-6/-10/3,3	1000	10	3,3	22	8,74	253
CHGT/4/6-1000-6/-14/4,5	1000	14	4,5	29,5	11,2	268
CHGT/4/6-1000-6/-16/6,5	1000	16	6,5	28,4	12,5	328
CHGT/4/6-1000-6/-20/8,5	1000	20	8,5	34,9	16,3	363
CHGT/4/6-1000-9/-6/2,2	1000	6	2,2	13,7	6,96	217
CHGT/4/6-1000-9/-10/3,3	1000	10	3,3	22	8,74	258
CHGT/4/6-1000-9/-14/4,5	1000	14	4,5	29,5	11,2	273
CHGT/4/6-1000-9/-16/6,5	1000	16	6,5	28,4	12,5	333
CHGT/4/6-1000-9/-20/8,5	1000	20	8,5	34,9	16,3	368
CHGT/4/6-1250-3/-6/2,2	1250	6	2,2	13,7	6,96	364
CHGT/4/6-1250-3/-10/3,3	1250	10	3,3	22	8,74	405
CHGT/4/6-1250-3/-14/4,5	1250	14	4,5	29,5	11,2	420
CHGT/4/6-1250-3/-16/6,5	1250	16	6,5	28,4	12,5	480
CHGT/4/6-1250-3/-20/8,5	1250	20	8,5	34,9	16,3	515
CHGT/4/6-1250-3/-26/9	1250	26	9	47,7	18,6	565
CHGT/4/6-1250-3/-34/12	1250	34	12	65,6	28	664

TECHNICAL CHARACTERISTICS - F400 - 4/6 poles - 1450/950 rpm (CONTINUATION)

Model	Diameter (mm)	Motor power		Full load current 400V (A)		Weight (kg)
		HS	LS	HS	LS	
CHGT/4/6-1250-6/-10/3,3	1250	10	3,3	22	8,74	410
CHGT/4/6-1250-6/-14/4,5	1250	14	4,5	29,5	11,2	425
CHGT/4/6-1250-6/-16/6,5	1250	16	6,5	28,4	12,5	485
CHGT/4/6-1250-6/-20/8,5	1250	20	8,5	34,9	16,3	520
CHGT/4/6-1250-6/-26/9	1250	26	9	47,7	18,6	570
CHGT/4/6-1250-6/-34/12	1250	34	12	65,6	28	669
CHGT/4/6-1250-6/-40/14	1250	40	14	75,5	29	723

Model	Diameter (mm)	Motor power		Full load current 400V (A)		Weight (kg)
		HS	LS	HS	LS	
CHGT/4/6-1250-9/-14/4,5	1250	14	4,5	29,5	11,2	430
CHGT/4/6-1250-9/-16/6,5	1250	16	6,5	28,4	12,5	490
CHGT/4/6-1250-9/-20/8,5	1250	20	8,5	34,9	16,3	525
CHGT/4/6-1250-9/-26/9	1250	26	9	47,7	18,6	575
CHGT/4/6-1250-9/-34/12	1250	34	12	65,6	28	674
CHGT/4/6-1250-9/-40/14	1250	40	14	75,5	29	728

TECHNICAL CHARACTERISTICS - F400 - 6/12 poles - 950/475 rpm

Model	Diameter (mm)	Motor power		Full load current 400V (A)		Weight (kg)
		HS	LS	HS	LS	
CHGT/6/12-630-6/-0,55/0,09	630	0,55	0,09	2,07	0,944	74
CHGT/6/12-630-6/-0,75/0,12	630	0,75	0,12	2,28	1,02	76
CHGT/6/12-710-5/-0,55/0,09	710	0,55	0,09	2,07	0,944	86
CHGT/6/12-710-5/-0,75/0,12	710	0,75	0,12	2,28	1,02	88
CHGT/6/12-710-5/-1,1/0,18	710	1,1	0,18	4,49	1,67	100
CHGT/6/12-710-7/-0,55/0,09	710	0,55	0,09	2,07	0,944	88
CHGT/6/12-710-7/-0,75/0,12	710	0,75	0,12	2,28	1,02	90
CHGT/6/12-710-7/-1,1/0,18	710	1,1	0,18	4,49	1,67	102
CHGT/6/12-800-3/-0,55/0,09	800	0,55	0,09	2,07	0,944	89
CHGT/6/12-800-3/-0,75/0,12	800	0,75	0,12	2,28	1,02	91
CHGT/6/12-800-3/-1,1/0,18	800	1,1	0,18	4,49	1,67	103
CHGT/6/12-800-3/-1,5/0,25	800	1,5	0,25	4,24	1,67	106
CHGT/6/12-800-6/-0,55/0,09	800	0,55	0,09	2,07	0,944	93
CHGT/6/12-800-6/-0,75/0,12	800	0,75	0,12	2,28	1,02	95
CHGT/6/12-800-6/-1,1/0,18	800	1,1	0,18	4,49	1,67	107
CHGT/6/12-800-6/-1,5/0,25	800	1,5	0,25	4,24	1,67	110
CHGT/6/12-800-6/-2,2/0,37	800	2,2	0,37	5,73	2,18	112
CHGT/6/12-800-9/-0,75/0,12	800	0,75	0,12	2,28	1,02	98
CHGT/6/12-800-9/-1,1/0,18	800	1,1	0,18	4,49	1,67	110
CHGT/6/12-800-9/-1,5/0,25	800	1,5	0,25	4,24	1,67	113
CHGT/6/12-800-9/-2,2/0,37	800	2,2	0,37	5,73	2,18	115
CHGT/6/12-800-9/-3/0,55	800	3	0,55	8,87	3,8	150
CHGT/6/12-900-3/-1,1/0,18	900	1,1	0,18	4,49	1,67	166
CHGT/6/12-900-3/-1,5/0,25	900	1,5	0,25	4,24	1,67	169

Model	Diameter (mm)	Motor power		Full load current 400V (A)		Weight (kg)
		HS	LS	HS	LS	
CHGT/6/12-900-6/-1,1/0,18	900	1,1	0,18	4,49	1,67	170
CHGT/6/12-900-6/-1,5/0,25	900	1,5	0,25	4,24	1,67	173
CHGT/6/12-900-6/-2,2/0,37	900	2,2	0,37	5,73	2,18	175
CHGT/6/12-900-6/-3/0,55	900	3	0,55	8,87	3,8	210
CHGT/6/12-900-9/-1,1/0,18	900	1,1	0,18	4,49	1,67	174
CHGT/6/12-900-9/-1,5/0,25	900	1,5	0,25	4,24	1,67	177
CHGT/6/12-900-9/-2,2/0,37	900	2,2	0,37	5,73	2,18	179
CHGT/6/12-900-9/-3/0,55	900	3	0,55	8,87	3,8	214
CHGT/6/12-1000-3/-1,1/0,18	1000	1,1	0,18	4,49	1,67	163
CHGT/6/12-1000-3/-1,5/0,25	1000	1,5	0,25	4,24	1,67	166
CHGT/6/12-1000-3/-2,2/0,37	1000	2,2	0,37	5,73	2,18	168
CHGT/6/12-1000-3/-3/0,55	1000	3	0,55	8,87	3,8	203
CHGT/6/12-1000-3/-4/0,65	1000	4	0,65	9,31	2,94	203
CHGT/6/12-1000-6/-1,1/0,18	1000	1,1	0,18	4,49	1,67	168
CHGT/6/12-1000-6/-1,5/0,25	1000	1,5	0,25	4,24	1,67	171
CHGT/6/12-1000-6/-2,2/0,37	1000	2,2	0,37	5,73	2,18	173
CHGT/6/12-1000-6/-3/0,55	1000	3	0,55	8,87	3,8	208
CHGT/6/12-1000-6/-4/0,65	1000	4	0,65	9,31	2,94	208
CHGT/6/12-1000-6/-6/1,2	1000	6	1,2	13,4	5,58	256
CHGT/6/12-1000-9/-1,5/0,25	1000	1,5	0,25	4,24	1,67	176
CHGT/6/12-1000-9/-2,2/0,37	1000	2,2	0,37	5,73	2,18	178
CHGT/6/12-1000-9/-3/0,55	1000	3	0,55	8,87	3,8	213
CHGT/6/12-1000-9/-4/0,65	1000	4	0,65	9,31	2,94	213
CHGT/6/12-1000-9/-6/1,2	1000	6	1,2	13,4	5,58	261
CHGT/6/12-1000-9/-7,5/1,5	1000	7,5	1,5	16,4	6,49	268

TECHNICAL CHARACTERISTICS - F400 - 6/12 poles - 950/475 rpm

Model	Diameter (mm)	Motor power		Full load current 400V (A)		Weight (kg)
		HS	LS	HS	LS	

CHGT/6/12-1250-3/-1,5/0,25	1250	1,5	0,25	4,24	1,67	323
CHGT/6/12-1250-3/-2,2/0,37	1250	2,2	0,37	5,73	2,18	325
CHGT/6/12-1250-3/-3/0,55	1250	3	0,55	8,87	3,8	360
CHGT/6/12-1250-3/-4/0,65	1250	4	0,65	9,31	2,94	360
CHGT/6/12-1250-3/-6/1,2	1250	6	1,2	13,4	5,58	408
CHGT/6/12-1250-3/-7,5/1,5	1250	7,5	1,5	16,4	6,49	415
CHGT/6/12-1250-3/-12/2,4	1250	12	2,4	23,4	8,07	485

CHGT/6/12-1250-6/-3/0,55	1250	3	0,55	8,87	3,8	365
CHGT/6/12-1250-6/-4/0,65	1250	4	0,65	9,31	2,94	365
CHGT/6/12-1250-6/-6/1,2	1250	6	1,2	13,4	5,58	413
CHGT/6/12-1250-6/-7,5/1,5	1250	7,5	1,5	16,4	6,49	420
CHGT/6/12-1250-6/-12/2,4	1250	12	2,4	23,4	8,07	490
CHGT/6/12-1250-6/-17/4,3	1250	17	4,3	31	10,2	570

Model	Diameter (mm)	Motor power		Full load current 400V (A)		Weight (kg)
		HS	LS	HS	LS	

CHGT/6/12-1250-9/-4/0,65	1250	4	0,65	9,31	2,94	370
CHGT/6/12-1250-9/-6/1,2	1250	6	1,2	13,4	5,58	418
CHGT/6/12-1250-9/-7,5/1,5	1250	7,5	1,5	16,4	6,49	425
CHGT/6/12-1250-9/-12/2,4	1250	12	2,4	23,4	8,07	495
CHGT/6/12-1250-9/-17/4,3	1250	17	4,3	31	10,2	575
CHGT/6/12-1250-9/-20/5	1250	20	5	39	14,3	610

TECHNICAL CHARACTERISTICS - F300 - 4 poles - 1450 rpm

Model	Diameter (mm)	Motor power	Full load current at 400V (A)	Weight (kg)
-------	---------------	-------------	-------------------------------	-------------

CHGT/4-400-6/-0,25	400	0,25	0,6	54
CHGT/4-450-6/-0,25	450	0,25	0,6	57
CHGT/4-450-6/-0,37	450	0,37	0,87	58
CHGT/4-450-6/-0,55	450	0,55	1,27	59

CHGT/4-500-6/-0,55	500	0,55	1,27	61
CHGT/4-500-6/-0,75	500	0,75	1,62	65
CHGT/4-500-6/-1,1	500	1,1	2,35	70

CHGT/4-560-6/-0,55	560	0,55	1,27	60
CHGT/4-560-6/-0,75	560	0,75	1,62	64
CHGT/4-560-6/-1,1	560	1,1	2,35	69
CHGT/4-560-6/-1,5	560	1,5	3,17	72
CHGT/4-560-6/-2,2	560	2,2	4,56	81

CHGT/4-630-6/-0,75	630	0,75	1,62	68
CHGT/4-630-6/-1,1	630	1,1	2,35	73
CHGT/4-630-6/-1,5	630	1,5	3,17	76
CHGT/4-630-6/-2,2	630	2,2	4,56	85
CHGT/4-630-6/-3	630	3	6,15	91

CHGT/4-710-3/-0,75	710	0,75	1,62	78
CHGT/4-710-3/-1,1	710	1,1	2,35	83
CHGT/4-710-3/-1,5	710	1,5	3,17	86
CHGT/4-710-3/-2,2	710	2,2	4,56	95
CHGT/4-710-3/-3	710	3	6,15	101

Model	Diameter (mm)	Motor power	Full load current at 400V (A)	Weight (kg)
-------	---------------	-------------	-------------------------------	-------------

CHGT/4-710-6/-1,1	710	1,1	2,35	86
CHGT/4-710-6/-1,5	710	1,5	3,17	89
CHGT/4-710-6/-2,2	710	2,2	4,56	98
CHGT/4-710-6/-3	710	3	6,15	104
CHGT/4-710-6/-4	710	4	8,03	110

CHGT/4-800-3/-1,1	800	1,1	2,35	88
CHGT/4-800-3/-1,5	800	1,5	3,17	91
CHGT/4-800-3/-2,2	800	2,2	4,56	100
CHGT/4-800-3/-3	800	3	6,15	106
CHGT/4-800-3/-4	800	4	8,03	112
CHGT/4-800-3/-5,5	800	5,5	10,4	134

CHGT/4-800-6/-1,5	800	1,5	3,17	95
CHGT/4-800-6/-2,2	800	2,2	4,56	104
CHGT/4-800-6/-3	800	3	6,15	110
CHGT/4-800-6/-4	800	4	8,03	116
CHGT/4-800-6/-5,5	800	5,5	10,4	138
CHGT/4-800-6/-7,5	800	7,5	13,9	146

CHGT/4-800-9/-2,2	800	2,2	4,56	107
CHGT/4-800-9/-3	800	3	6,15	113
CHGT/4-800-9/-4	800	4	8,03	119
CHGT/4-800-9/-5,5	800	5,5	10,4	141
CHGT/4-800-9/-7,5	800	7,5	13,9	149

TECHNICAL CHARACTERISTICS - F300 - 4 poles - 1450 rpm (CONTINUATION)

Model	Diameter (mm)	Motor power	Full load current at 400V (A)	Weight (kg)
CHGT/4-900-3/-2,2	900	2,2	4,56	163
CHGT/4-900-3/-3	900	3	6,15	169
CHGT/4-900-3/-4	900	4	8,03	175
CHGT/4-900-3/-5,5	900	5,5	10,4	197
CHGT/4-900-3/-7,5	900	7,5	13,9	205
CHGT/4-900-6/-3	900	3	6,15	173
CHGT/4-900-6/-4	900	4	8,03	179
CHGT/4-900-6/-5,5	900	5,5	10,4	201
CHGT/4-900-6/-7,5	900	7,5	13,9	209
CHGT/4-900-6/-11	900	11	20,9	248
CHGT/4-900-9/-5,5	900	5,5	10,4	205
CHGT/4-900-9/-7,5	900	7,5	13,9	213
CHGT/4-900-9/-11	900	11	20,9	252
CHGT/4-900-9/-15	900	15	27,9	274
CHGT/4-1000-3/-3	1000	3	6,15	166
CHGT/4-1000-3/-4	1000	4	8,03	172
CHGT/4-1000-3/-5,5	1000	5,5	10,4	194
CHGT/4-1000-3/-7,5	1000	7,5	13,9	202
CHGT/4-1000-3/-11	1000	11	20,9	241
CHGT/4-1000-6/-4	1000	4	8,03	177
CHGT/4-1000-6/-5,5	1000	5,5	10,4	199
CHGT/4-1000-6/-7,5	1000	7,5	13,9	207
CHGT/4-1000-6/-11	1000	11	20,9	246
CHGT/4-1000-6/-15	1000	15	27,9	268
CHGT/4-1000-6/-18,5	1000	18,5	35,1	301

Model	Diameter (mm)	Motor power	Full load current at 400V (A)	Weight (kg)
CHGT/4-1000-9/-7,5	1000	7,5	13,9	212
CHGT/4-1000-9/-11	1000	11	20,9	251
CHGT/4-1000-9/-15	1000	15	27,9	273
CHGT/4-1000-9/-18,5	1000	18,5	35,1	306
CHGT/4-1000-9/-22	1000	22	41	323
CHGT/4-1250-3/-7,5	1250	7,5	13,9	359
CHGT/4-1250-3/-11	1250	11	20,9	398
CHGT/4-1250-3/-15	1250	15	27,9	420
CHGT/4-1250-3/-18,5	1250	18,5	35,1	453
CHGT/4-1250-3/-22	1250	22	41	470
CHGT/4-1250-3/-30	1250	30	57,1	513
CHGT/4-1250-6/-15	1250	15	27,9	425
CHGT/4-1250-6/-18,5	1250	18,5	35,1	458
CHGT/4-1250-6/-22	1250	22	41	475
CHGT/4-1250-6/-30	1250	30	57,1	518
CHGT/4-1250-6/-37	1250	37	66,8	655
CHGT/4-1250-6/-45	1250	45	80,9	690
CHGT/4-1250-9/-15	1250	15	27,9	430
CHGT/4-1250-9/-18,5	1250	18,5	35,1	463
CHGT/4-1250-9/-22	1250	22	41	480
CHGT/4-1250-9/-30	1250	30	57,1	523
CHGT/4-1250-9/-37	1250	37	66,8	660
CHGT/4-1250-9/-45	1250	45	80,9	695

TECHNICAL CHARACTERISTICS - F300 - 6 poles - 950 rpm

Model	Diameter (mm)	Motor power	Full load current at 400V (A)	Weight (kg)
CHGT/6-560-6/-0,55	560	0,55	1,49	63
CHGT/6-630-6/-0,55	630	0,55	1,49	67
CHGT/6-630-6/-0,75	630	0,75	1,93	75
CHGT/6-630-6/-1,1	630	1,1	2,69	82
CHGT/6-710-3/-0,55	710	0,55	1,49	77
CHGT/6-710-3/-0,75	710	0,75	1,93	85
CHGT/6-710-6/-0,55	710	0,55	1,49	80
CHGT/6-710-6/-0,75	710	0,75	1,93	88
CHGT/6-710-6/-1,1	710	1,1	2,69	95

Model	Diameter (mm)	Motor power	Full load current at 400V (A)	Weight (kg)
CHGT/6-800-3/-0,75	800	0,75	1,93	90
CHGT/6-800-3/-1,1	800	1,1	2,69	97
CHGT/6-800-3/-1,5	800	1,5	3,7	100
CHGT/6-800-6/-0,75	800	0,75	1,93	94
CHGT/6-800-6/-1,1	800	1,1	2,69	101
CHGT/6-800-6/-1,5	800	1,5	3,7	104
CHGT/6-800-6/-2,2	800	2,2	5,22	118

TECHNICAL CHARACTERISTICS - F300 - 6 poles - 950 rpm (CONTINUATION)

Model	Diameter (mm)	Motor power	Full load current at 400V (A)		Weight (kg)	Model	Diameter (mm)	Motor power	Full load current at 400V (A)		Weight (kg)
CHGT/6-800-9/-0,75	800	0,75	1,93		97	CHGT/6-1000-9/-2,2	1000	2,2	5,22		184
CHGT/6-800-9/-1,1	800	1,1	2,69		104	CHGT/6-1000-9/-3	1000	3	6,91		203
CHGT/6-800-9/-1,5	800	1,5	3,7		107	CHGT/6-1000-9/-4	1000	4	9,11		208
CHGT/6-800-9/-2,2	800	2,2	5,22		121	CHGT/6-1000-9/-5,5	1000	5,5	12,9		216
CHGT/6-800-9/-3	800	3	6,91		140	CHGT/6-1000-9/-7,5	1000	7,5	14,8		256
CHGT/6-900-3/-1,5	900	1,5	3,7		163	CHGT/6-1250-3/-2,2	1250	2,2	5,22		331
CHGT/6-900-3/-2,2	900	2,2	5,22		177	CHGT/6-1250-3/-3	1250	3	6,91		350
CHGT/6-900-6/-1,5	900	1,5	3,7		167	CHGT/6-1250-3/-4	1250	4	9,11		355
CHGT/6-900-6/-2,2	900	2,2	5,22		181	CHGT/6-1250-3/-5,5	1250	5,5	12,9		363
CHGT/6-900-6/-3	900	3	6,91		200	CHGT/6-1250-3/-7,5	1250	7,5	14,8		403
CHGT/6-900-9/-1,5	900	1,5	3,7		171	CHGT/6-1250-3/-11	1250	11	21,9		425
CHGT/6-900-9/-2,2	900	2,2	5,22		185	CHGT/6-1250-6/-4	1250	4	9,11		360
CHGT/6-900-9/-3	900	3	6,91		204	CHGT/6-1250-6/-5,5	1250	5,5	12,9		368
CHGT/6-900-9/-5,5	900	5,5	12,9		217	CHGT/6-1250-6/-7,5	1250	7,5	14,8		408
CHGT/6-1000-3/-1,5	1000	1,5	3,7		160	CHGT/6-1250-6/-11	1250	11	21,9		430
CHGT/6-1000-3/-2,2	1000	2,2	5,22		174	CHGT/6-1250-6/-15	1250	15	28,2		475
CHGT/6-1000-3/-3	1000	3	6,91		193	CHGT/6-1250-9/-5,5	1250	5,5	12,9		373
CHGT/6-1000-3/-4	1000	4	9,11		198	CHGT/6-1250-9/-7,5	1250	7,5	14,8		413
CHGT/6-1000-6/-1,5	1000	1,5	3,7		165	CHGT/6-1250-9/-11	1250	11	21,9		435
CHGT/6-1000-6/-2,2	1000	2,2	5,22		179	CHGT/6-1250-9/-15	1250	15	28,2		480
CHGT/6-1000-6/-3	1000	3	6,91		198	CHGT/6-1250-9/-18,5	1250	18,5	35,9		510
CHGT/6-1000-6/-4	1000	4	9,11		203	CHGT/6-1250-9/-22	1250	22	42,4		520
CHGT/6-1000-6/-5,5	1000	5,5	12,9		211						

TECHNICAL CHARACTERISTICS - F300 - 4/8 poles - 1450/730 rpm

Model	Diameter (mm)	Motor power		Full load current 400V (A)		Weight (kg)	Model	Diameter (mm)	Motor power		Full load current 400V (A)		Weight (kg)
		HS	LS	HS	LS				HS	LS	HS	LS	
CHGT/4/8-400-6/-0,55/0,09	400	0,55	0,09	1,7	0,837	60	CHGT/4/8-630-6/-0,55/0,09	630	0,55	0,09	1,7	0,837	68
CHGT/4/8-450-6/-0,55/0,09	450	0,55	0,09	1,7	0,837	63	CHGT/4/8-630-6/-0,75/0,12	630	0,75	0,12	1,86	0,833	68
CHGT/4/8-500-6/-0,55/0,09	500	0,55	0,09	1,7	0,837	65	CHGT/4/8-630-6/-1,1/0,18	630	1,1	0,18	2,73	1,21	80
CHGT/4/8-500-6/-0,75/0,12	500	0,75	0,12	1,86	0,833	65	CHGT/4/8-630-6/-1,5/0,25	630	1,5	0,25	3,65	1,6	83
CHGT/4/8-500-6/-1,1/0,18	500	1,1	0,18	2,73	1,21	77	CHGT/4/8-630-6/-2,2/0,37	630	2,2	0,37	4,7	1,66	91
CHGT/4/8-560-6/-0,55/0,09	560	0,55	0,09	1,7	0,837	64	CHGT/4/8-630-6/-3/0,55	630	3	0,55	6,29	2,35	92
CHGT/4/8-560-6/-0,75/0,12	560	0,75	0,12	1,86	0,833	64	CHGT/4/8-630-6/-4/0,75	630	4	0,75	8,44	2,25	99
CHGT/4/8-560-6/-1,1/0,18	560	1,1	0,18	2,73	1,21	76	CHGT/4/8-710-3/-0,55/0,09	710	0,55	0,09	1,7	0,837	78
CHGT/4/8-560-6/-1,5/0,25	560	1,5	0,25	3,65	1,6	79	CHGT/4/8-710-3/-0,75/0,12	710	0,75	0,12	1,86	0,833	78
CHGT/4/8-560-6/-2,2/0,37	560	2,2	0,37	4,7	1,66	87	CHGT/4/8-710-3/-1,1/0,18	710	1,1	0,18	2,73	1,21	90
							CHGT/4/8-710-3/-1,5/0,25	710	1,5	0,25	3,65	1,6	93
							CHGT/4/8-710-3/-2,2/0,37	710	2,2	0,37	4,7	1,66	101
							CHGT/4/8-710-3/-3/0,55	710	3	0,55	6,29	2,35	102

TECHNICAL CHARACTERISTICS - F300 - 4/8 poles - 1450/730 rpm (CONTINUATION)

Model	Diameter (mm)	Motor power		Full load current 400V (A)		Weight (kg)	Model	Diameter (mm)	Motor power		Full load current 400V (A)		Weight (kg)
		HS	LS	HS	LS				HS	LS	HS	LS	
CHGT/4/8-710-6/-0,75/0,12	710	0,75	0,12	1,86	0,833	81	CHGT/4/8-1000-3/-2,2/0,37	1000	2,2	0,37	4,7	1,66	166
CHGT/4/8-710-6/-1,1/0,18	710	1,1	0,18	2,73	1,21	93	CHGT/4/8-1000-3/-3/0,55	1000	3	0,55	6,29	2,35	167
CHGT/4/8-710-6/-1,5/0,25	710	1,5	0,25	3,65	1,6	96	CHGT/4/8-1000-3/-4/0,75	1000	4	0,75	8,44	2,25	174
CHGT/4/8-710-6/-2,2/0,37	710	2,2	0,37	4,7	1,66	104	CHGT/4/8-1000-3/-5,5/1,1	1000	5,5	1,1	11,7	3,7	196
CHGT/4/8-710-6/-3/0,55	710	3	0,55	6,29	2,35	105	CHGT/4/8-1000-3/-7,5/1,5	1000	7,5	1,5	15,9	4,72	209
CHGT/4/8-710-6/-4/0,75	710	4	0,75	8,44	2,25	112	CHGT/4/8-1000-3/-11/3	1000	11	3	21	7	240
CHGT/4/8-800-3/-1,1/0,18	800	1,1	0,18	2,73	1,21	95	CHGT/4/8-1000-6/-4/0,75	1000	4	0,75	8,44	2,25	179
CHGT/4/8-800-3/-1,5/0,25	800	1,5	0,25	3,65	1,6	98	CHGT/4/8-1000-6/-5,5/1,1	1000	5,5	1,1	11,7	3,7	201
CHGT/4/8-800-3/-2,2/0,37	800	2,2	0,37	4,7	1,66	106	CHGT/4/8-1000-6/-7,5/1,5	1000	7,5	1,5	15,9	4,72	214
CHGT/4/8-800-3/-3/0,55	800	3	0,55	6,29	2,35	107	CHGT/4/8-1000-6/-11/3	1000	11	3	21	7	245
CHGT/4/8-800-3/-4/0,75	800	4	0,75	8,44	2,25	114	CHGT/4/8-1000-6/-14/3,5	1000	14	3,5	26,5	8,45	264
CHGT/4/8-800-6/-1,5/0,25	800	1,5	0,25	3,65	1,6	102	CHGT/4/8-1000-6/-17/4,3	1000	17	4,3	33,4	12,7	295
CHGT/4/8-800-6/-2,2/0,37	800	2,2	0,37	4,7	1,66	110	CHGT/4/8-1000-6/-20/5	1000	20	5	38,6	14,1	310
CHGT/4/8-800-6/-3/0,55	800	3	0,55	6,29	2,35	111	CHGT/4/8-1000-9/-5,5/1,1	1000	5,5	1,1	11,7	3,7	206
CHGT/4/8-800-6/-4/0,75	800	4	0,75	8,44	2,25	118	CHGT/4/8-1000-9/-7,5/1,5	1000	7,5	1,5	15,9	4,72	219
CHGT/4/8-800-6/-5,5/1,1	800	5,5	1,1	11,7	3,7	140	CHGT/4/8-1000-9/-11/3	1000	11	3	21	7	250
CHGT/4/8-800-6/-7,5/1,5	800	7,5	1,5	15,9	4,72	153	CHGT/4/8-1000-9/-14/3,5	1000	14	3,5	26,5	8,45	269
CHGT/4/8-800-9/-2,2/0,37	800	2,2	0,37	4,7	1,66	113	CHGT/4/8-1000-9/-17/4,3	1000	17	4,3	33,4	12,7	300
CHGT/4/8-800-9/-3/0,55	800	3	0,55	6,29	2,35	114	CHGT/4/8-1000-9/-20/5	1000	20	5	38,6	14,1	315
CHGT/4/8-800-9/-4/0,75	800	4	0,75	8,44	2,25	121	CHGT/4/8-1250-3/-5,5/1,1	1250	5,5	1,1	11,7	3,7	353
CHGT/4/8-800-9/-5,5/1,1	800	5,5	1,1	11,7	3,7	143	CHGT/4/8-1250-3/-7,5/1,5	1250	7,5	1,5	15,9	4,72	366
CHGT/4/8-800-9/-7,5/1,5	800	7,5	1,5	15,9	4,72	156	CHGT/4/8-1250-3/-11/3	1250	11	3	21	7	397
CHGT/4/8-900-3/-2,2/0,37	900	2,2	0,37	4,7	1,66	169	CHGT/4/8-1250-3/-14/3,5	1250	14	3,5	26,5	8,45	416
CHGT/4/8-900-3/-3/0,55	900	3	0,55	6,29	2,35	170	CHGT/4/8-1250-3/-17/4,3	1250	17	4,3	33,4	12,7	447
CHGT/4/8-900-3/-4/0,75	900	4	0,75	8,44	2,25	177	CHGT/4/8-1250-3/-20/5	1250	20	5	38,6	14,1	462
CHGT/4/8-900-3/-5,5/1,1	900	5,5	1,1	11,7	3,7	199	CHGT/4/8-1250-3/-28/6,5	1250	28	6,5	52	18	520
CHGT/4/8-900-3/-7,5/1,5	900	7,5	1,5	15,9	4,72	212	CHGT/4/8-1250-6/-11/3	1250	11	3	21	7	402
CHGT/4/8-900-6/-2,2/0,37	900	2,2	0,37	4,7	1,66	173	CHGT/4/8-1250-6/-14/3,5	1250	14	3,5	26,5	8,45	421
CHGT/4/8-900-6/-3/0,55	900	3	0,55	6,29	2,35	174	CHGT/4/8-1250-6/-17/4,3	1250	17	4,3	33,4	12,7	452
CHGT/4/8-900-6/-4/0,75	900	4	0,75	8,44	2,25	181	CHGT/4/8-1250-6/-20/5	1250	20	5	38,6	14,1	467
CHGT/4/8-900-6/-5,5/1,1	900	5,5	1,1	11,7	3,7	203	CHGT/4/8-1250-6/-28/6,5	1250	28	6,5	52	18	525
CHGT/4/8-900-6/-7,5/1,5	900	7,5	1,5	15,9	4,72	216	CHGT/4/8-1250-6/-30/8	1250	30	8	56,5	21,8	555
CHGT/4/8-900-6/-11/3	900	11	3	21	7	247	CHGT/4/8-1250-6/-37/9,2	1250	37	9,2	74,2	25,4	658
CHGT/4/8-900-9/-4/0,75	900	4	0,75	8,44	2,25	185	CHGT/4/8-1250-6/-44/11	1250	44	11	80,2	27,2	715
CHGT/4/8-900-9/-5,5/1,1	900	5,5	1,1	11,7	3,7	207	CHGT/4/8-1250-9/-14/3,5	1250	14	3,5	26,5	8,45	426
CHGT/4/8-900-9/-7,5/1,5	900	7,5	1,5	15,9	4,72	220	CHGT/4/8-1250-9/-17/4,3	1250	17	4,3	33,4	12,7	457
CHGT/4/8-900-9/-11/3	900	11	3	21	7	251	CHGT/4/8-1250-9/-20/5	1250	20	5	38,6	14,1	472
CHGT/4/8-900-9/-14/3,5	900	14	3,5	26,5	8,45	270	CHGT/4/8-1250-9/-28/6,5	1250	28	6,5	52	18	530
							CHGT/4/8-1250-9/-30/8	1250	30	8	56,5	21,8	560
							CHGT/4/8-1250-9/-37/9,2	1250	37	9,2	74,2	25,4	663
							CHGT/4/8-1250-9/-44/11	1250	44	11	80,2	27,2	720

TECHNICAL CHARACTERISTICS - F300 - 4/6 poles - 1450/950 rpm

Model	Diameter (mm)	Motor power		Full load current 400V (A)		Weight (kg)
		HS	LS	HS	LS	
CHGT/4/6-400-6/-0,55/0,2	400	0,55	0,2	1,75	1,05	56
CHGT/4/6-450-6/-0,55/0,2	450	0,55	0,2	1,75	1,05	59
CHGT/4/6-500-6/-0,55/0,2	500	0,55	0,2	1,75	1,05	61
CHGT/4/6-500-6/-0,75/0,25	500	0,75	0,25	1,94	1,32	62
CHGT/4/6-500-6/-1,1/0,3	500	1,1	0,3	2,84	1,49	66
CHGT/4/6-560-6/-0,55/0,2	560	0,55	0,2	1,75	1,05	60
CHGT/4/6-560-6/-0,75/0,25	560	0,75	0,25	1,94	1,32	61
CHGT/4/6-560-6/-1,1/0,3	560	1,1	0,3	2,84	1,49	65
CHGT/4/6-560-6/-1,5/0,37	560	1,5	0,37	3,65	1,62	69
CHGT/4/6-630-6/-0,55/0,2	630	0,55	0,2	1,75	1,05	64
CHGT/4/6-630-6/-0,75/0,25	630	0,75	0,25	1,94	1,32	65
CHGT/4/6-630-6/-1,1/0,3	630	1,1	0,3	2,84	1,49	69
CHGT/4/6-630-6/-1,5/0,37	630	1,5	0,37	3,65	1,62	73
CHGT/4/6-630-6/-2,2/0,7	630	2,2	0,7	4,91	2,48	80
CHGT/4/6-630-6/-3/1	630	3	1	6,85	3,86	89
CHGT/4/6-710-3/-0,55/0,2	710	0,55	0,2	1,75	1,05	74
CHGT/4/6-710-3/-0,75/0,25	710	0,75	0,25	1,94	1,32	75
CHGT/4/6-710-3/-1,1/0,3	710	1,1	0,3	2,84	1,49	79
CHGT/4/6-710-3/-1,5/0,37	710	1,5	0,37	3,65	1,62	83
CHGT/4/6-710-3/-2,2/0,7	710	2,2	0,7	4,91	2,48	90
CHGT/4/6-710-3/-3/1	710	3	1	6,85	3,86	99
CHGT/4/6-710-6/-0,75/0,25	710	0,75	0,25	1,94	1,32	78
CHGT/4/6-710-6/-1,1/0,3	710	1,1	0,3	2,84	1,49	82
CHGT/4/6-710-6/-1,5/0,37	710	1,5	0,37	3,65	1,62	86
CHGT/4/6-710-6/-2,2/0,7	710	2,2	0,7	4,91	2,48	93
CHGT/4/6-710-6/-3/1	710	3	1	6,85	3,86	102
CHGT/4/6-800-3/-1,1/0,3	800	1,1	0,3	2,84	1,49	84
CHGT/4/6-800-3/-1,5/0,37	800	1,5	0,37	3,65	1,62	88
CHGT/4/6-800-3/-2,2/0,7	800	2,2	0,7	4,91	2,48	95
CHGT/4/6-800-3/-3/1	800	3	1	6,85	3,86	104
CHGT/4/6-800-3/-4,5/1,5	800	4,5	1,5	10,2	5,38	136
CHGT/4/6-800-6/-1,5/0,37	800	1,5	0,37	3,65	1,62	92
CHGT/4/6-800-6/-2,2/0,7	800	2,2	0,7	4,91	2,48	99
CHGT/4/6-800-6/-3/1	800	3	1	6,85	3,86	108
CHGT/4/6-800-6/-4,5/1,5	800	4,5	1,5	10,2	5,38	140
CHGT/4/6-800-6/-6/2,2	800	6	2,2	13,7	6,96	151

Model	Diameter (mm)	Motor power		Full load current 400V (A)		Weight (kg)
		HS	LS	HS	LS	
CHGT/4/6-800-9/-2,2/0,7	800	2,2	0,7	4,91	2,48	102
CHGT/4/6-800-9/-3/1	800	3	1	6,85	3,86	111
CHGT/4/6-800-9/-4,5/1,5	800	4,5	1,5	10,2	5,38	143
CHGT/4/6-800-9/-6/2,2	800	6	2,2	13,7	6,96	154
CHGT/4/6-900-3/-2,2/0,7	900	2,2	0,7	4,91	2,48	158
CHGT/4/6-900-3/-3/1	900	3	1	6,85	3,86	167
CHGT/4/6-900-3/-4,5/1,5	900	4,5	1,5	10,2	5,38	199
CHGT/4/6-900-3/-6/2,2	900	6	2,2	13,7	6,96	210
CHGT/4/6-900-3/-10/3,3	900	10	3,3	22	8,74	251
CHGT/4/6-900-6/-2,2/0,7	900	2,2	0,7	4,91	2,48	162
CHGT/4/6-900-6/-3/1	900	3	1	6,85	3,86	171
CHGT/4/6-900-6/-4,5/1,5	900	4,5	1,5	10,2	5,38	203
CHGT/4/6-900-6/-6/2,2	900	6	2,2	13,7	6,96	214
CHGT/4/6-900-6/-10/3,3	900	10	3,3	22	8,74	255
CHGT/4/6-900-6/-14/4,5	900	14	4,5	29,5	11,2	270
CHGT/4/6-900-9/-4,5/1,5	900	4,5	1,5	10,2	5,38	207
CHGT/4/6-900-9/-6/2,2	900	6	2,2	13,7	6,96	218
CHGT/4/6-900-9/-10/3,3	900	10	3,3	22	8,74	259
CHGT/4/6-900-9/-14/4,5	900	14	4,5	29,5	11,2	274
CHGT/4/6-1000-3/-2,2/0,7	1000	2,2	0,7	4,91	2,48	155
CHGT/4/6-1000-3/-3/1	1000	3	1	6,85	3,86	164
CHGT/4/6-1000-3/-4,5/1,5	1000	4,5	1,5	10,2	5,38	196
CHGT/4/6-1000-3/-6/2,2	1000	6	2,2	13,7	6,96	207
CHGT/4/6-1000-3/-10/3,3	1000	10	3,3	22	8,74	248
CHGT/4/6-1000-3/-14/4,5	1000	14	4,5	29,5	11,2	263
CHGT/4/6-1000-6/-4,5/1,5	1000	4,5	1,5	10,2	5,38	201
CHGT/4/6-1000-6/-6/2,2	1000	6	2,2	13,7	6,96	212
CHGT/4/6-1000-6/-10/3,3	1000	10	3,3	22	8,74	253
CHGT/4/6-1000-6/-14/4,5	1000	14	4,5	29,5	11,2	268
CHGT/4/6-1000-6/-16/6,5	1000	16	6,5	28,4	12,5	328
CHGT/4/6-1000-6/-20/8,5	1000	20	8,5	34,9	16,3	363
CHGT/4/6-1000-9/-6/2,2	1000	6	2,2	13,7	6,96	217
CHGT/4/6-1000-9/-10/3,3	1000	10	3,3	22	8,74	258
CHGT/4/6-1000-9/-14/4,5	1000	14	4,5	29,5	11,2	273
CHGT/4/6-1000-9/-16/6,5	1000	16	6,5	28,4	12,5	333
CHGT/4/6-1000-9/-20/8,5	1000	20	8,5	34,9	16,3	368

TECHNICAL CHARACTERISTICS - F300 - 4/6 poles - 1450/950 rpm (CONTINUATION)

Model	Diameter (mm)	Motor power		Full load current 400V (A)		Weight (kg)
		HS	LS	HS	LS	
CHGT/4/6-1250-3/-6/2,2	1250	6	2,2	13,7	6,96	364
CHGT/4/6-1250-3/-10/3,3	1250	10	3,3	22	8,74	405
CHGT/4/6-1250-3/-14/4,5	1250	14	4,5	29,5	11,2	420
CHGT/4/6-1250-3/-16/6,5	1250	16	6,5	28,4	12,5	480
CHGT/4/6-1250-3/-20/8,5	1250	20	8,5	34,9	16,3	515
CHGT/4/6-1250-3/-26/9	1250	26	9	47,7	18,6	565
CHGT/4/6-1250-3/-34/12	1250	34	12	65,6	28	664

Model	Diameter (mm)	Motor power		Full load current 400V (A)		Weight (kg)
		HS	LS	HS	LS	
CHGT/4/6-1250-9/-14/4,5	1250	14	4,5	29,5	11,2	430
CHGT/4/6-1250-9/-16/6,5	1250	16	6,5	28,4	12,5	490
CHGT/4/6-1250-9/-20/8,5	1250	20	8,5	34,9	16,3	525
CHGT/4/6-1250-9/-26/9	1250	26	9	47,7	18,6	575
CHGT/4/6-1250-9/-34/12	1250	34	12	65,6	28	674
CHGT/4/6-1250-9/-40/14	1250	40	14	75,5	29	728

CHGT/4/6-1250-6/-10/3,3	1250	10	3,3	22	8,74	410
CHGT/4/6-1250-6/-14/4,5	1250	14	4,5	29,5	11,2	425
CHGT/4/6-1250-6/-16/6,5	1250	16	6,5	28,4	12,5	485
CHGT/4/6-1250-6/-20/8,5	1250	20	8,5	34,9	16,3	520
CHGT/4/6-1250-6/-26/9	1250	26	9	47,7	18,6	570
CHGT/4/6-1250-6/-34/12	1250	34	12	65,6	28	669
CHGT/4/6-1250-6/-40/14	1250	40	14	75,5	29	723

TECHNICAL CHARACTERISTICS - F300 - 6/12 poles - 950/475 rpm

Model	Diameter (mm)	Motor power		Full load current 400V (A)		Weight (kg)
		HS	LS	HS	LS	
CHGT/6/12-560-6/-0,55/0,09	560	0,55	0,09	2,07	0,944	70
CHGT/6/12-630-6/-0,55/0,09	630	0,55	0,09	2,07	0,944	74
CHGT/6/12-630-6/-0,75/0,12	630	0,75	0,12	2,28	1,02	76
CHGT/6/12-710-3/-0,55/0,09	710	0,55	0,09	2,07	0,944	84
CHGT/6/12-710-3/-0,75/0,12	710	0,75	0,12	2,28	1,02	86
CHGT/6/12-710-6/-0,55/0,09	710	0,55	0,09	2,07	0,944	87
CHGT/6/12-710-6/-0,75/0,12	710	0,75	0,12	2,28	1,02	89
CHGT/6/12-710-6/-1,1/0,18	710	1,1	0,18	4,49	1,67	101
CHGT/6/12-800-3/-0,55/0,09	800	0,55	0,09	2,07	0,944	89
CHGT/6/12-800-3/-0,75/0,12	800	0,75	0,12	2,28	1,02	91
CHGT/6/12-800-6/-0,55/0,09	800	0,55	0,09	2,07	0,944	93
CHGT/6/12-800-6/-0,75/0,12	800	0,75	0,12	2,28	1,02	95
CHGT/6/12-800-6/-1,1/0,18	800	1,1	0,18	4,49	1,67	107
CHGT/6/12-800-6/-1,5/0,25	800	1,5	0,25	4,24	1,67	110
CHGT/6/12-800-6/-2,2/0,37	800	2,2	0,37	5,73	2,18	112

Model	Diameter (mm)	Motor power		Full load current 400V (A)		Weight (kg)
		HS	LS	HS	LS	
CHGT/6/12-800-9/-1,1/0,18	800	1,1	0,18	4,49	1,67	110
CHGT/6/12-800-9/-1,5/0,25	800	1,5	0,25	4,24	1,67	113
CHGT/6/12-800-9/-2,2/0,37	800	2,2	0,37	5,73	2,18	115
CHGT/6/12-800-9/-3/0,55	800	3	0,55	8,87	3,8	150
CHGT/6/12-900-3/-1,1/0,18	900	1,1	0,18	4,49	1,67	166
CHGT/6/12-900-3/-1,5/0,25	900	1,5	0,25	4,24	1,67	169
CHGT/6/12-900-6/-1,1/0,18	900	1,1	0,18	4,49	1,67	170
CHGT/6/12-900-6/-1,5/0,25	900	1,5	0,25	4,24	1,67	173
CHGT/6/12-900-6/-2,2/0,37	900	2,2	0,37	5,73	2,18	175
CHGT/6/12-900-6/-3/0,55	900	3	0,55	8,87	3,8	210
CHGT/6/12-900-9/-1,1/0,18	900	1,1	0,18	4,49	1,67	174
CHGT/6/12-900-9/-1,5/0,25	900	1,5	0,25	4,24	1,67	177
CHGT/6/12-900-9/-2,2/0,37	900	2,2	0,37	5,73	2,18	179
CHGT/6/12-900-9/-3/0,55	900	3	0,55	8,87	3,8	214
CHGT/6/12-1000-3/-1,1/0,18	1000	1,1	0,18	4,49	1,67	163
CHGT/6/12-1000-3/-1,5/0,25	1000	1,5	0,25	4,24	1,67	166
CHGT/6/12-1000-3/-2,2/0,37	1000	2,2	0,37	5,73	2,18	168
CHGT/6/12-1000-3/-3/0,55	1000	3	0,55	8,87	3,8	203
CHGT/6/12-1000-3/-4/0,65	1000	4	0,65	9,31	2,94	203

TECHNICAL CHARACTERISTICS - F300 - 6/12 poles - 950/475 rpm (CONTINUATION)

Model	Diameter (mm)	Motor power		Full load current 400V (A)		Weight (kg)
		HS	LS	HS	LS	

CHGT/6/12-1000-6/-1,1/0,18	1000	1,1	0,18	4,49	1,67	168
CHGT/6/12-1000-6/-1,5/0,25	1000	1,5	0,25	4,24	1,67	171
CHGT/6/12-1000-6/-2,2/0,37	1000	2,2	0,37	5,73	2,18	173
CHGT/6/12-1000-6/-3/0,55	1000	3	0,55	8,87	3,8	208
CHGT/6/12-1000-6/-4/0,65	1000	4	0,65	9,31	2,94	208
CHGT/6/12-1000-6/-6/1,2	1000	6	1,2	13,4	5,58	256

CHGT/6/12-1000-9/-1,5/0,25	1000	1,5	0,25	4,24	1,67	176
CHGT/6/12-1000-9/-2,2/0,37	1000	2,2	0,37	5,73	2,18	178
CHGT/6/12-1000-9/-3/0,55	1000	3	0,55	8,87	3,8	213
CHGT/6/12-1000-9/-4/0,65	1000	4	0,65	9,31	2,94	213
CHGT/6/12-1000-9/-6/1,2	1000	6	1,2	13,4	5,58	261
CHGT/6/12-1000-9/-7,5/1,5	1000	7,5	1,5	16,4	6,49	268

CHGT/6/12-1250-3/-2,2/0,37	1250	2,2	0,37	5,73	2,18	325
CHGT/6/12-1250-3/-3/0,55	1250	3	0,55	8,87	3,8	360
CHGT/6/12-1250-3/-4/0,65	1250	4	0,65	9,31	2,94	360
CHGT/6/12-1250-3/-6/1,2	1250	6	1,2	13,4	5,58	408
CHGT/6/12-1250-3/-7,5/1,5	1250	7,5	1,5	16,4	6,49	415
CHGT/6/12-1250-3/-12/2,4	1250	12	2,4	23,4	8,07	485

Model	Diameter (mm)	Motor power		Full load current 400V (A)		Weight (kg)
		HS	LS	HS	LS	

CHGT/6/12-1250-6/-3/0,55	1250	3	0,55	8,87	3,8	365
CHGT/6/12-1250-6/-4/0,65	1250	4	0,65	9,31	2,94	365
CHGT/6/12-1250-6/-6/1,2	1250	6	1,2	13,4	5,58	413
CHGT/6/12-1250-6/-7,5/1,5	1250	7,5	1,5	16,4	6,49	420
CHGT/6/12-1250-6/-12/2,4	1250	12	2,4	23,4	8,07	490
CHGT/6/12-1250-6/-17/4,3	1250	17	4,3	31	10,2	570

CHGT/6/12-1250-9/-4/0,65	1250	4	0,65	9,31	2,94	370
CHGT/6/12-1250-9/-6/1,2	1250	6	1,2	13,4	5,58	418
CHGT/6/12-1250-9/-7,5/1,5	1250	7,5	1,5	16,4	6,49	425
CHGT/6/12-1250-9/-12/2,4	1250	12	2,4	23,4	8,07	495
CHGT/6/12-1250-9/-17/4,3	1250	17	4,3	31	10,2	575
CHGT/6/12-1250-9/-20/5	1250	20	5	39	14,3	610

DIMENSIONS (mm)

Models 400 to 800

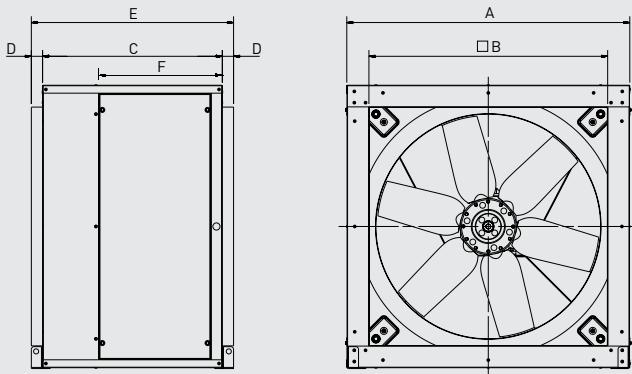

Model	A	□B	C	D	E	F
400	509	423	440	40	520	304
450	567,6	473	483	40	563	317
500	638	523	525	40	605	331
560	718,6	583	570	40	650	370
630	808	653	570	40	650	370
710	907,6	750	640	40	720	438
800	1007,6	850	640	40	720	438

Models 900 to 1250

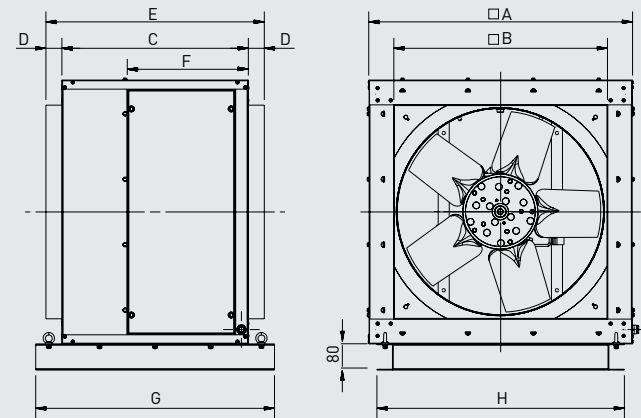

Model	□A	□B	C	D	E	F	G	H
900	1126,5	950	700	50	800	503	860	1076,5
1000	1256,5	1055	700	50	800	503	860	1206,5
1250	1476,5	1275	900	50	1000	310	1060	1426,5

MOUNTING ACCESSORIES



PER-CR CHGT/CGT

Back pressure louvre with steel frame and resistant light-weight aluminium blades, with a device which allows a perfect and coordinate opening of the blades. RAL 7012 color. These louvres include safety net. Louvres to be used jointly with CHGT and CGT fans to avoid air returns in parallel installations.

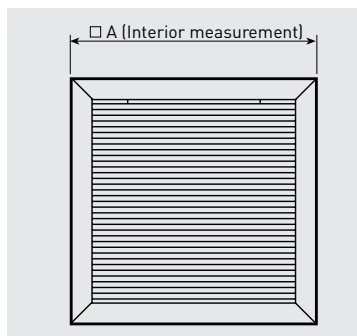

Model	□ A
PER-CR CHGT/CGT-400	430
PER-CR CHGT/CGT-450	480
PER-CR CHGT/CGT-500	530
PER-CR CHGT/CGT-560	587
PER-CR CHGT/CGT-630	657
PER-CR CHGT/CGT-710	754
PER-CR CHGT/CGT-800	854
PER-CR CHGT/CGT-900	954
PER-CR CHGT/CGT-1000	1059
PER-CR CHGT/CGT-1250	1279

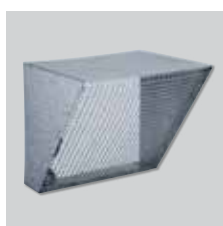

CVD CHGT/CGT

Protection guards. Wire protection guards for mounting on the inlet or discharge sides of the cabinets.

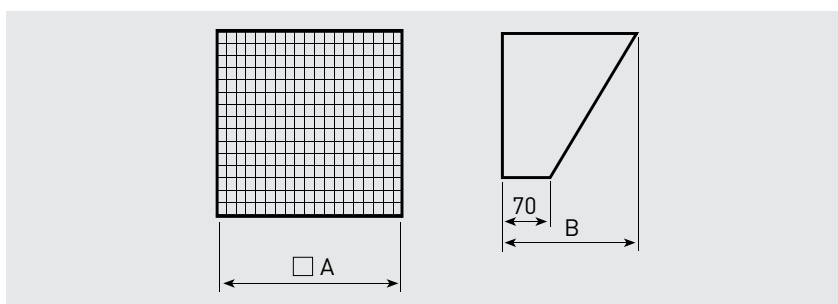

Model cabinet	Inlet and discharge		
	Protection guard model	A	B
CHGT-400	CVD CHGT/CGT-400	424	313,5
CHGT-450	CVD CHGT/CGT-450	474	341,5
CHGT-500	CVD CHGT/CGT-500	524	369,5
CHGT-560	CVD CHGT/CGT-560	584	403,5
CHGT-630	CVD CHGT/CGT-630	654	422,5
CHGT-710	CVD CHGT/CGT-710	751	503,8
CHGT-800	CVD CHGT/CGT-800	851,5	560,2
CHGT-900	CVD CHGT/CGT-900	951,5	616,2
CHGT-1000	CVD CHGT/CGT-1000	1056,5	675
CHGT-1250	CVD CHGT/CGT-1250	1276,5	798,3

Dimensions in mm.

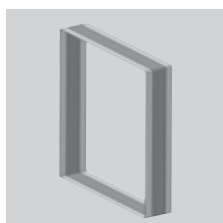

ACOP RECT CHGT/CGT F400

Rectangular flexible connector.

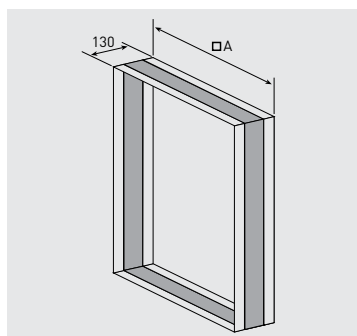

Dimensions in mm.

Model cabinet	□ A
ACOP RECT CHGT/CGT 400 F400	424
ACOP RECT CHGT/CGT 450 F400	474
ACOP RECT CHGT/CGT 500 F400	524
ACOP RECT CHGT/CGT 560 F400	584
ACOP RECT CHGT/CGT 630 F400	654
ACOP RECT CHGT/CGT 710 F400	751
ACOP RECT CHGT/CGT 800 F400	851
ACOP RECT CHGT/CGT 900 F400	951
ACOP RECT CHGT/CGT 1000 F400	1056
ACOP RECT CHGT/CGT 1250 F400	1276